

# SUMMIT



## REFRIGERATOR – FREEZERS

**Models FFBF100W  
FFBF101SS**

### *Use and Care Guide*

**BEFORE USE, PLEASE READ AND FOLLOW ALL SAFETY RULES AND OPERATING INSTRUCTIONS.**

Keep proof of original sales date (such as your sales slip) with this manual to establish the warranty period.

Write the Model and Serial Numbers here. You'll find them on a plate located either on the back of the appliance or on an interior wall.

Model No. \_\_\_\_\_

Serial No. \_\_\_\_\_

**Felix Storch, Inc.  
770 Garrison Avenue  
Bronx, NY 10474  
[www.summitappliance.com](http://www.summitappliance.com)**

## IMPORTANT SAFEGUARDS



Before the refrigerator-freezer is used, it must be properly positioned and installed as described in this manual, so read the manual carefully. To reduce the risk of fire, electrical shock or injury when using this appliance, follow basic precautions, including the following:

### **DANGER**

- Plug into a grounded 3-prong outlet, do not remove grounding prong, do not use an adapter, and do not use an extension cord.
- It is recommended that a separate circuit, serving only your refrigerator-freezer, be provided. Use receptacles that cannot be turned off by a switch or pull chain.
- Never clean refrigerator parts with flammable fluids. These fumes can create a fire hazard or explosion.
- Do not store or use gasoline or other flammable vapors and liquids inside or in the vicinity of this or any other appliance. The fumes can create a fire hazard or explosion.
- Do not use flammable sprays in the vicinity of this appliance.
- Before proceeding with cleaning and maintenance operations, make sure the power line of the unit is disconnected.
- Do not connect or disconnect the electric plug when your hands are wet.
- Unplug the appliance or disconnect power before cleaning or servicing. Failure to do so can result in electrical shock or death.
- Do not attempt to repair or replace any part of your refrigerator-freezer unless it is specifically recommended in this manual. All other servicing should be referred to a qualified technician.
- This appliance is CFC- and HFC-free and contains a small quantity of Isobutane (R600a) which is environmentally friendly but flammable. It does not damage the ozone layer, nor does it increase the greenhouse effect. Care must be taken during transportation and setting up of the appliance that no parts of the cooling system are damaged. Leaking coolant can ignite and may damage the eyes.
- In the event of any damage:
  - Avoid open flames and anything that creates a spark,
  - Disconnect from the electrical power line,
  - Air the room in which the appliance is located for several minutes, and
  - Contact the Service Department for advice.
- The more coolant there is in an appliance, the larger the room it should be installed in. In the event of a leakage, if the appliance is in a small room, there is the danger of combustible gases building up. For every ounce of coolant, at least 325 cubic feet of room space is required. The amount of coolant in the appliance is stated on the data plate either on the back of the appliance or on an interior wall. It is hazardous for anyone other than an authorized Service Person to carry out servicing or repairs to this appliance.
- Take serious care when handling, moving, and using the appliance to avoid either damaging the refrigerant tubing or increasing the risk of a leak.
- Replacing component parts and servicing shall be done by factory-authorized service personnel so as to minimize the risk of possible ignition due to incorrect parts or improper service.

- **DANGER!** *Risk of child entrapment!*

Child entrapment and suffocation are not problems of the past. Junked or abandoned refrigerators are still dangerous, even if they will "just sit in the garage a few days."

- √ **Before you throw away your old refrigerator:** Take off the doors. Leave the shelves in place so that children may not easily climb inside.
- √ Never allow children to operate, play with, or crawl inside the refrigerator.



- Use two or more people to move and install the refrigerator-freezer. Failure to do so can result in back or other injury.
- To ensure proper ventilation for your appliance, the front of the unit must be completely unobstructed. Choose a well-ventilated area with temperatures above 60°F (16°C) and below 90°F (32°C). This unit must be installed in an area protected from the elements, such as wind, rain, water spray or drips.
- The refrigerator-freezer should not be located next to ovens, grills or other sources of high heat.
- The appliance must be installed with all electrical, water and drain connections in accordance with state and local codes. A standard electrical supply (115 V AC only, 60 Hz), properly grounded in accordance with the National Electrical Code and local codes and ordinances, is required.
- Do not kink or pinch the power supply cord of the refrigerator-freezer.
- The fuse (or circuit breaker) size should be 15 amperes.
- It is important for the appliance to be leveled in order to work properly. You may need to make several adjustments to level it.
- Check for leaks after connection.
- Never allow children to operate, play with or crawl inside the refrigerator.
- This appliance is not intended for use by persons (including children) with reduced physical, sensory or mental capabilities, or lack of experience and knowledge, unless they have been given supervision or instruction concerning use of the appliance by a person responsible for their safety.
- **IMPORTANT:** Do not use mechanical devices or other means to accelerate the defrosting process, other than those recommended by the manufacturer.
- **IMPORTANT:** Do not damage the refrigerant circuit.
- **IMPORTANT:** Do not use electrical appliances inside the food storage compartments of the appliance unless they are of a type recommended by the manufacturer.
- Do not use solvent-based cleaning agents or abrasives on the interior. These cleaners may damage or discolor the interior.
- This type of refrigerator-freezer is widely used in places such as hotels, offices, student dormitories and houses. It is most suitable for refrigerating and storing food items. Do not use this apparatus for other than its intended purpose.

**SAVE THESE INSTRUCTIONS**

# 1. INSTALLATION

## 1.1 Location

When selecting a position for your unit you should make sure the floor is flat and firm, and the room is well ventilated. Avoid locating your unit near a heat source, e.g. stove, boiler or radiator. Also avoid direct sunlight as it may increase the electrical consumption. Extremely cold ambient temperatures may also cause the unit not to perform properly. This unit is not designed for use in a garage or outdoor installation. Do not drape the unit with any covering.

When installing the unit, be sure that 7¼ in. of free space is left at both sides, 7¼ in. at the rear and 12 in. at the top of the unit. This will allow cold air to circulate around the appliance and improve the efficiency of the cooling process.

## 1.2 Reversing the Door Swing

**Tools Required:** Phillips screwdriver / Flat-bladed screwdriver / Hexagonal wrench



If you want to have the door swing reversed, we recommend that you contact a qualified technician. You should only try to reverse the door yourself if you believe that you are qualified to do so.

- ◆ Ensure the unit is unplugged and empty.
- ◆ Adjust the two leveling feet to their highest position.
- ◆ To take the door off it is necessary to tilt the unit backwards. You should rest the unit on something solid so that it will not slip during the door reversing process.
- ◆ All parts removed must be saved for the reinstallation of the door.
- ◆ Do not lay the unit flat as this may damage the coolant system.
- ◆ We recommend that 2 people handle the unit during assembly.

- 1) Remove the hinge cover. Unscrew and remove the top hinge.
- 2) Lift the freezer door up and away from the appliance.

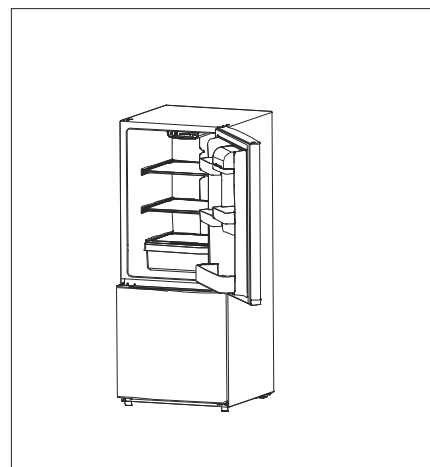
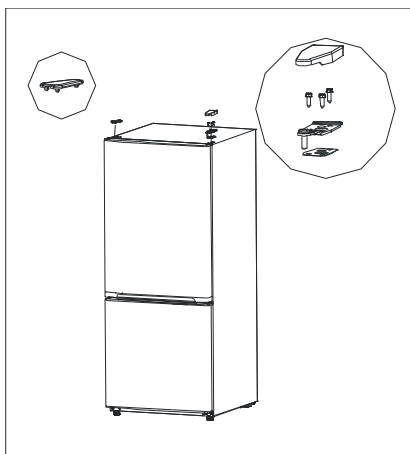

- 3) Remove the screws from the middle hinge. Lift the refrigerator door up and away from the appliance.

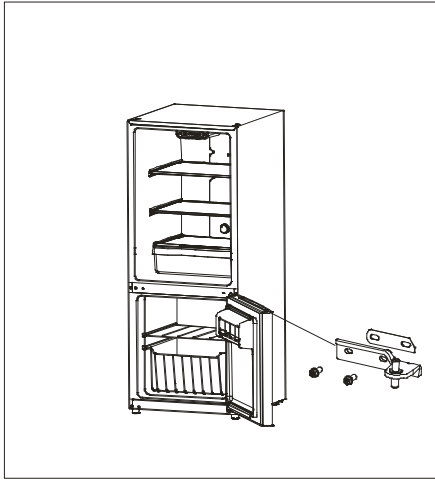

- 4) First loosen the screws and remove the right hinge and gasket. Take out the left hinge and remove the screws fixed to the left hinge and shim. Finally attach the left hinge and gasket using the screw holes on the left side of the refrigerator.

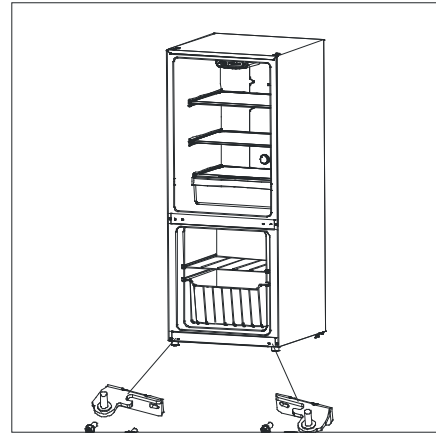

- 5) Remove the pin assembly from the bottom of the freezer and refrigerator doors. On the opposite side, attach the replacement pin assembly (located in the plastic bag with the Use and Care Manual) with a screwdriver. NOTE: You must re-use the screw from the pin assembly that is removed in this step when attaching the new assembly.

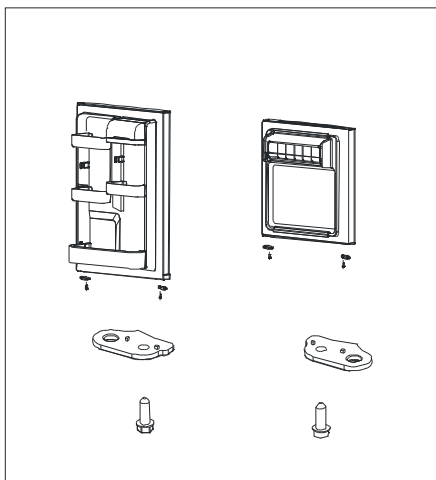

- 6) Place the freezer door on the bottom hinge. Be sure the door is aligned horizontally and vertically, and that the gasket seals on all sides before attaching the middle hinge. Attach the middle hinge using a screwdriver.



- 7) Place the refrigerator door on the middle hinge. Be sure the door is aligned horizontally and vertically, and that the gasket seals on all sides before attaching the top hinge. Attach the top hinge and replace the hinge cover.

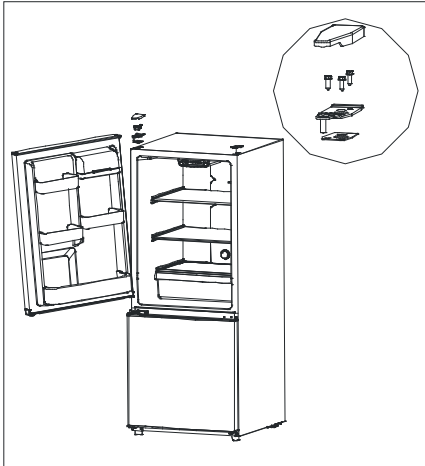

### 1.3 Door Space Requirements

The unit's door must be able to open fully as shown.

$$W \times D \geq 41.3'' \times 42.9''$$

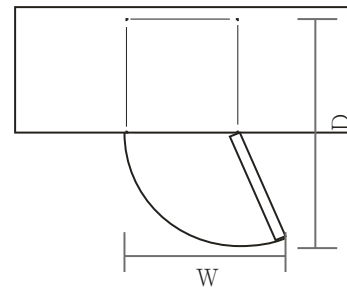

### 1.4 Leveling the Unit

If the appliance is not leveled during installation, the doors may not close or seal properly, causing cooling, frost, or moisture problems. It is very important for the refrigerator-freezer to be level in order to function properly.

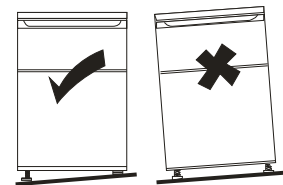

To level your refrigerator-freezer, you may either turn the adjustable foot clockwise to raise that side of the appliance or turn it counter-clockwise to lower that side.

NOTE: Having someone push against the top of the refrigerator-freezer will take some weight off the adjustable foot and make it easier to turn.

### 1.5 Cleaning before Use

Wipe the inside of the unit with a weak solution of bicarbonate soda. Then rinse with warm water using a wrung-out sponge or cloth. Wash the shelves and salad bin in warm soapy water and dry completely before replacing in the unit. Clean the exterior of the unit with a damp cloth.

If you require more information refer to the *Cleaning* section.

## 1.6 Before Using Your Unit

The refrigerator requires 115V/60Hz AC power, voltage fluctuations beyond the range of 98 to 132V will cause a malfunction or even damage, so a 750 W automatic voltage regulator must be installed in concert with the AC power.

To promote safe usage, do not damage the power cord and do not use the appliance when the power cord is damaged or the plug is worn.

To prevent damage to the product and avoid a fire hazard, do not put flammable, explosive, volatile or highly corrosive items in the refrigerator.

To avoid a fire hazard, do not place flammable items near the refrigerator.

This product is a household refrigerator and is suitable only for the storage of food. According to national standards, household refrigerators must not be used for other purposes, such as the storage of blood, drugs or biological products.

Do not place bottled or sealed containers of liquids such as beer and other beverages in the freezer to prevent bursts and other damage.

Before placing any food in your unit, turn it on and wait for 24 hours to make sure it is working properly and to allow time for it to fall to the correct temperature. Do not overfill the unit.



### ◆ Before plugging in

Check that your electric socket is compatible with the plug supplied with the unit.

### ◆ Before turning on!

Do not turn on the unit until two hours after moving it. The coolant fluid needs time to settle.

## 1.7 Interior Accessories

Various glass or plastic storage shelves are included with your appliance – different models have different combinations.

You should always slide one of the full-size glass storage shelves into the lowest set of guides, above the fruit and vegetable containers, and keep it in this position. To do this, pull the storage shelf forward until it can be swiveled upward or downward and removed.

Please do the same in reverse to insert the shelf at a different height.



In order to make the most of the volume of the fresh food and frozen-food storage compartments, the user can remove one or more shelves or drawers out of the appliance, according to daily use.

## 2. PRODUCT OVERVIEW

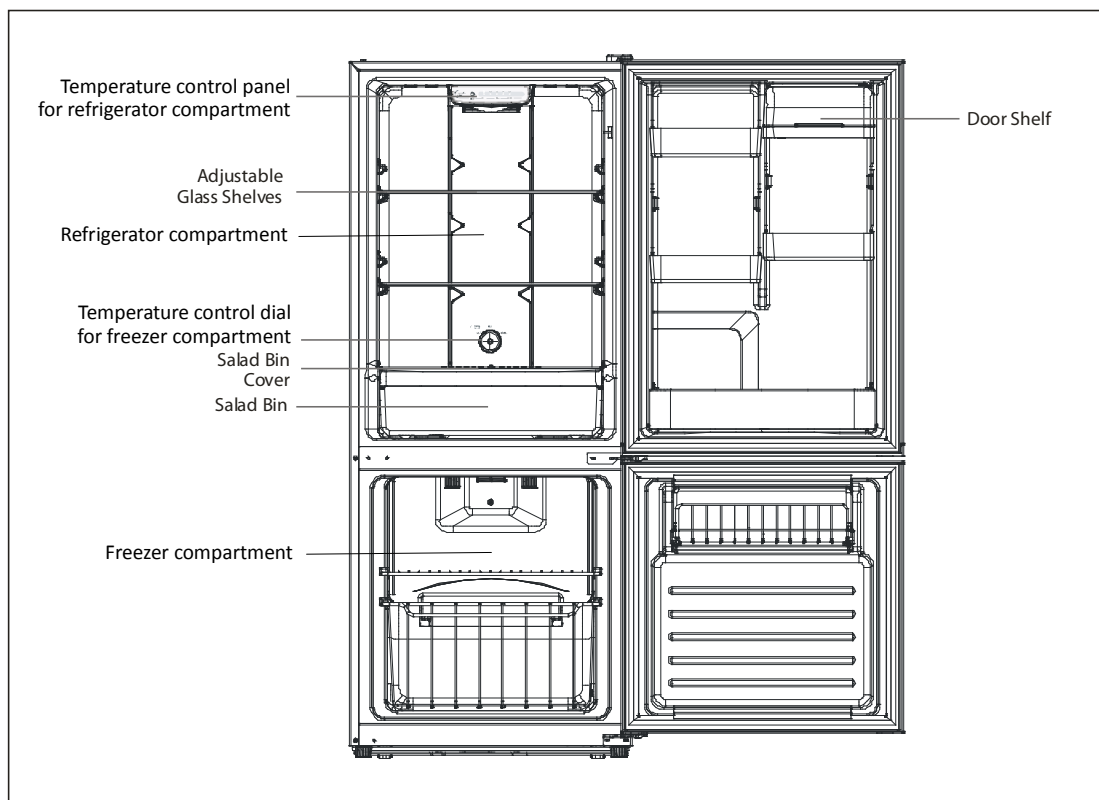

\*All images in this instruction manual are for general information only; please refer to your individual unit for details.

## 3. OPERATION

### HMI (Human-Machine Interface) and keys operation

The keys in the HMI and display layout are referred to in the following figure :

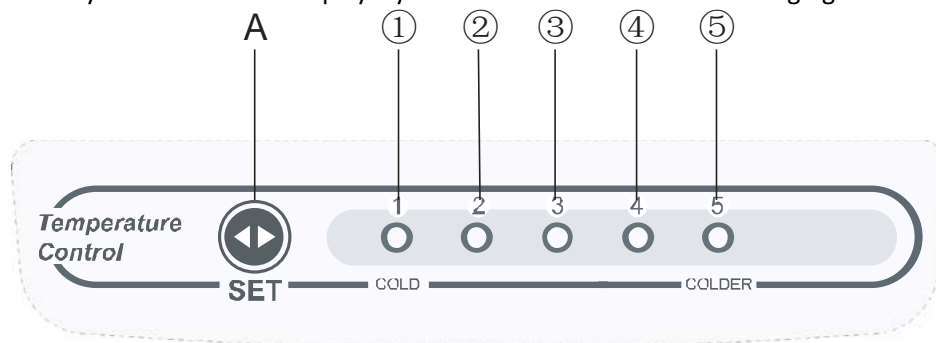

### 3.1 Key

A: SET position set key

### 3.2 Display screen

- ① Shift 1
- ② Shift 2
- ③ Shift 3
- ④ Shift 4
- ⑤ Shift 5



### 3.3 Display

- ◆ Once initially powered on, the display screen (including the key light) is on full display for 3 seconds, and then displays the actual operation position.
- ◆ Normal operation display  
In case of a failure, the appropriate LED lights in combination show the failure code (in recycling display); see “3.5 Fault indication” below.  
If there is no failure, the actual operation position of the refrigerator will be on display.

### 3.4 Shift setting

Each time the shift setting key A is pressed, the shift setting changes by one position. After the shift setting has been completed, the refrigerator will operate according to the set value after 5 seconds. From left to right, the set temperature becomes lower.

The shift regulation is :

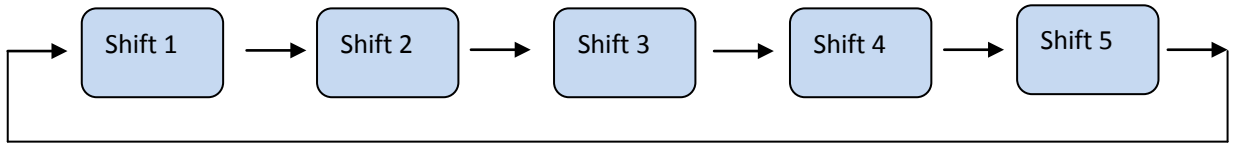

### 3.5 Fault indication

Display	Malfunction
LED1 and LED2 are lit	Refrigerator temperature sensor circuit
LED1 and LED3 are lit	Freezer defrost sensor
LED1 and LED4 are lit	Ambient temperature sensor

### 3.6 Temperature Control

On the **refrigerator compartment control panel** (above), Shift 1 is the warmest setting while Shift 5 is the coldest.

For normal ambient temperatures, Shift 3 should be selected.

On the **freezer compartment control knob** (at right), select the **Mid** position when the ambient temperature is normal.

If the ambient temperature will be lower than 55°F for an extended period of time, the control knob should be placed at the **COLDER** position.

If the ambient temperature is higher than 90°F for a long time or a fast freeze is needed, place the control knob in the **COLD** position.

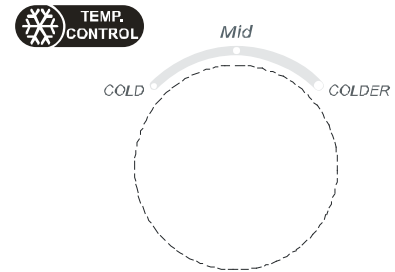

### 3.7 Fruit and Vegetable Box Humidity Control

By toggling the **humidity-adjusting control** (at right), you can adjust the humidity in the fruit and vegetable drawer.



## 4. CLEANING

### 4.1 Defrosting

Auto-defrost for Frost-free Refrigerator

### 4.2 Cleaning the Interior and the Exterior of the Unit

- ◆ Remove all the shelves and the salad bin. To remove the salad bin, first remove the lower door shelf.

- ◆ Wipe the inside of the unit with a weak solution of bicarbonate soda and then rinse with warm water using a wrung-out sponge or cloth. Wipe completely dry before replacing the shelves and salad bin.
- ◆ For model FFBF100W, use a damp cloth to clean the exterior, and then wipe with a standard furniture polish. Make sure that the door is closed to avoid the polish getting on the magnetic door seal or inside the unit. For model FFBF101SS, use a cleaner recommended for stainless steel.
- ◆ The grille of the condenser at the back of the unit and the adjacent components can be vacuumed using a soft brush attachment.

### **4.3 Cleaning Tips**

Condensation may appear on the outside of the unit. This may be due to a change in room temperature. Wipe off any moisture residue. If the problem continues, please contact a qualified technician for assistance.

## **5. MAINTENANCE**

### **5.1 Changing the Internal Light Bulb**

Bulb must be replaced by professionals.

Illuminating lamp power: Max 15W

### **5.2 Care When Handling / Moving Your Unit**

Hold the unit around its sides or base when moving it. Under no circumstances should it be lifted by holding the edges of the top surface.

Do not turn the unit upside down or place it horizontally. Do not shake the refrigerator. The carrying angle must not be greater than 45°.

### **5.3 Servicing**

The unit should be serviced only by an authorized technician; only approved spare parts should be used. Under no circumstances should you attempt to repair the unit yourself. Repairs carried out by inexperienced persons may cause injury or serious malfunction. Contact a qualified technician.

### **5.4 Switching Off for Long Periods of Time**

When the unit is not in use for a long period of time, disconnect it from the power supply, remove all stored food and clean the appliance, leaving the door ajar to prevent unpleasant smells.

## 6. TROUBLESHOOTING

In case of a malfunction, you can solve many common problems easily.

### **If your refrigerator-freezer does not operate:**

Is the power cord plugged in?

### **If the doors will not close completely:**

Are the drawers out of position?

Are the gaskets dirty?

Is the refrigerator-freezer level?

### **If the refrigerator-freezer is noisy when running:**

Check that the appliance is level and is not in contact with another appliance or article of kitchen furniture.

### **If the refrigerator-freezer does not cool sufficiently:**

Have the doors been opened too often, or have they been left open for a while? If so, it will take time for the refrigerator-freezer to reach its set temperature.

Has the airflow at the rear of the appliance been reduced due to insufficient clearance?

### **The following characteristics should not be looked upon as a problem:**

- A gentle trickling sound caused by coolant flowing through the pipes.
- Compressor operating at high temperature.

### **Requesting Assistance or Service:**

If the problem is not due to one of the items listed in *Troubleshooting*, contact the dealer or authorized service company. You can also call our SUMMIT® Customer Service line at **1-800-932-4267** weekdays from 8:30 AM to 5:00PM (ET).

## Limited Warranty

### **ONE-YEAR LIMITED WARRANTY**

Within the 48 contiguous United States, for one year from the date of purchase, when this appliance is operated and maintained according to instructions attached to or furnished with the product, warrantor will pay for factory-specified parts and repair labor to correct defects in materials or workmanship. Service must be provided by a designated service company. Outside the 48 states, all parts are warranted for one year from manufacturing defects. Plastic parts, shelves and cabinets are warranted to be manufactured to commercially acceptable standards, and are not covered from damage during handling or breakage.

### **5-YEAR COMPRESSOR WARRANTY**

1. The compressor is covered for 5 years.
2. Replacement does not include labor.

#### ***ITEMS WARRANTOR WILL NOT PAY FOR:***

1. Service calls to correct the installation of your appliance, to instruct you how to use your appliance, to replace or repair fuses or to correct wiring or plumbing.
2. Service calls to repair or replace appliance light bulbs or broken shelves. Consumable parts (such as filters) are excluded from warranty coverage.
3. Damage resulting from accident, alteration, misuse, abuse, fire, flood, acts of God, improper installation, installation not in accordance with electrical or plumbing codes, or use of products not approved by warrantor.
4. Replacement parts or repair labor costs for units operated outside the United States.
5. Repairs to parts or systems resulting from unauthorized modifications made to the appliance.
6. Expenses for travel and transportation for product service in remote locations.
7. The removal and reinstallation of your appliance if it is installed in an inaccessible location or is not installed in accordance with published installation instructions.

### **DISCLAIMER OF IMPLIED WARRANTIES - LIMITATION OF REMEDIES**

CUSTOMER'S SOLE AND EXCLUSIVE REMEDY UNDER THIS LIMITED WARRANTY SHALL BE PRODUCT REPAIR AS PROVIDED HEREIN. IMPLIED WARRANTIES, INCLUDING WARRANTIES OF MERCHANTABILITY OR FITNESS FOR A PARTICULAR PURPOSE, ARE LIMITED TO ONE YEAR. WARRANTOR SHALL NOT BE LIABLE FOR INCIDENTAL OR CONSEQUENTIAL DAMAGES. SOME STATES DO NOT ALLOW THE EXCLUSION OR LIMITATION OF INCIDENTAL OR CONSEQUENTIAL DAMAGES, OR LIMITATIONS ON THE DURATION OF IMPLIED WARRANTIES OF MERCHANTABILITY OR FITNESS, SO THESE EXCLUSIONS OR LIMITATIONS MAY NOT APPLY TO YOU. THIS WARRANTY GIVES YOU SPECIFIC LEGAL RIGHTS AND YOU MAY ALSO HAVE OTHER RIGHTS, WHICH VARY FROM STATE TO STATE.

**WARNING!** This product may contain chemicals known to the state of California to cause cancer or birth defects or other reproductive harm. For more information, visit: [www.summitappliance.com/prop65](http://www.summitappliance.com/prop65)

Chemicals known by the manufacturer to be present in this product in concentrations higher than threshold limits: NONE.

**FELIX STORCH, INC.**  
770 Garrison Avenue  
Bronx, NY 10474  
Phone: (718) 893-3900  
Fax: (844) 478-8799  
[www.summitappliance.com](http://www.summitappliance.com)

# SUMMIT

For parts and accessory ordering,  
troubleshooting and helpful hints, visit:  
[www.summitappliance.com/support](http://www.summitappliance.com/support)