



# BIM26IF



25" x 14.88" x 16.75" (H x W x D)

Built-in undercounter manual defrost icemaker with panel-ready door; no drain required

### Highlights:

Panel-ready door lets you customize the unit for a seamless look that integrates into your kitchen

Produces 15 lbs of crescent-shaped ice and stores up to 12 lbs

Convenient drain-free design allows more flexibility in positioning the unit

### Product Features:

No-Drain 15" Wide Icemaker	Built-in or undercounter capable icemaker designed for kitchen islands, home bars, break rooms, health offices, RVs, and even boat kitchens.
Built-In capable	Make the best use of space by installing your icemaker under the counter
Large capacity	Produces 15 lbs of crescent-shaped ice and stores up to 12 lbs
Drain-free design	Convenient design allows more flexibility in positioning the unit
Manual defrost	Static cooling system helps to keep ice frozen for longer periods of time compared to other systems
Panel-ready door	Integrated stainless steel door frame allows you to mount full overlay panels over the door to create a custom look that can blend into cabinetry with no exposed frame (panel size: 20 1/2" H x 14 15/16" H and at least 3/4" thick; maximum weight: 10 lbs.)
Sealed back	Space-saving design with easier cleanability
Standard water hookup	Operates with a standard 1/4" OD water supply line
Ice scoop included	Large ice scoop and holder included for your convenience



## BIM261F Specifications:

Overview	
Height of Cabinet	24.5" (62 cm)
Height to Hinge Cap	25.0" (64 cm)
Width	14.88" (38 cm)
Width with Door Open	15.13" (38 cm)
Depth	16.75" (43 cm)
Depth with door at 90°	32.25" (82 cm)
Defrost Type	Manual
Door	Panel-Ready
Cabinet	Black
US Electrical Safety	ETL
Canadian Electrical Safety	ETL-C
Amps	1.2
Voltage/Frequency	115 V AC/60 Hz
Weight	50.0 lbs. (23 kg)
Parts & Labor Warranty	1 Year
Compressor Warranty	5 Years
UPC	761101144801
Icemaker	
Door Swing	RHD
Reversible	Factory Reversible
Height Adjustable	No
Daily Ice Production	15.0 lbs. (7 kg)
Ice Storage Capacity	12.0 lbs. (5 kg)
Ice Shape	Crescent
Size of Cube	7/8" x 7/8" x 2-3/8"
Number of Ice Cube Sizes	1
Refrigerant Type	R600a
Refrigerant Amount	1.69 oz.
High Side PSI	120.0
Low Side PSI	55.0
Interior Height	12.25" (31 cm)
Interior Width	11.0" (28 cm)
Interior Depth	12.25" (31 cm)
Level Legs	4

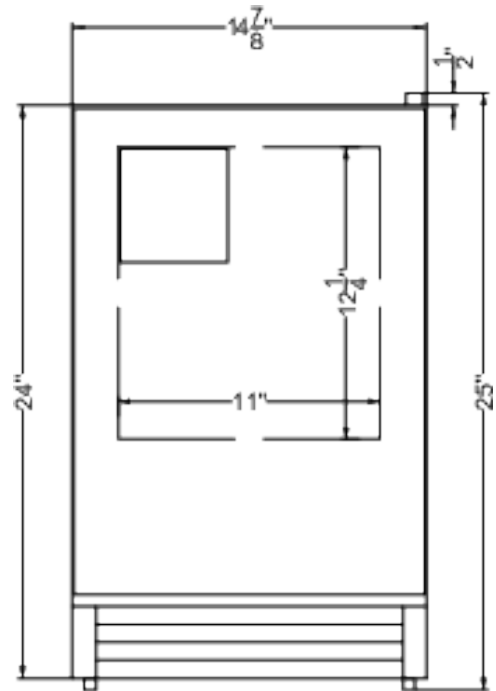
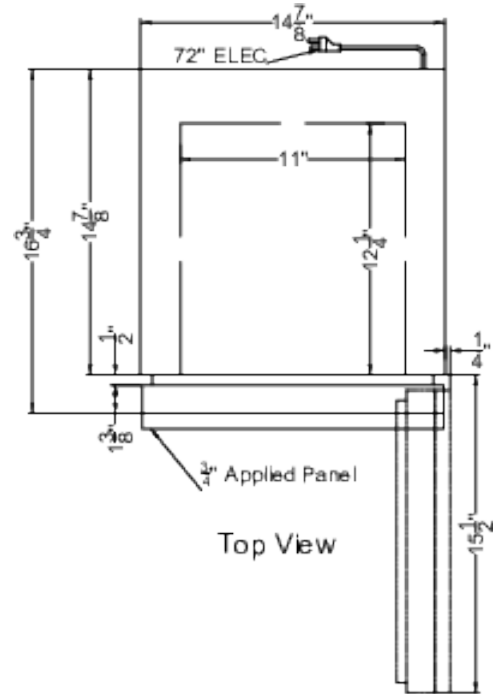

Front View