



WINE CELLAR

Model SWC1545



Instruction Manual

BEFORE USE, PLEASE READ AND FOLLOW ALL SAFETY RULES AND OPERATING INSTRUCTIONS.

Write Serial No. (on back of unit) here:

Felix Storch, Inc.
770 Garrison Avenue
Bronx, NY 10474
www.summitappliance.com

TABLE OF CONTENTS

Appliance Safety	3
Important Safeguards	3-4
Location of Parts	5
Installation Instructions	5-7
Before Using Your Appliance	5
Installation of Your Appliance	5-6
Electrical Connection	6
Extension Cord	6
Installing the Stainless Steel Handle	7
Operating Your Appliance	7-10
Recommended Temperature Settings	7
Control Panel	8
Setting the Temperature Controls	9
Wine Shelves	9
Storage	9
Door Lock	10
Operating Problems	10
Start-Up	
During Operation	
Care and Maintenance	11
Routine Maintenance	
Power Failure	
Vacation Time	
Moving Your Appliance	
Energy-Saving Tips	
Troubleshooting	12
Limited Warranty	13

APPLIANCE SAFETY

Your safety and the safety of others are very important.

We have provided many important safety messages in this manual and on your appliance. Always read and obey all safety messages.



This is the Safety Alert Symbol. The symbol alerts you to potential hazards that can kill or injure you and others. All safety messages will follow the Safety Alert Symbol and either the words **DANGER** or **WARNING**.



DANGER means that failure to heed this safety statement may result in severe personal injury or death.



WARNING means that failure to heed this safety statement may result in extensive product damage, serious personal injury, or death.

Safety messages will alert you about the potential hazard, tell you how to reduce the chance of injury, and let you know what can happen if the instructions are not followed.

IMPORTANT SAFEGUARDS



Before the appliance is used, it must be properly positioned and installed as described in this manual, so read the manual carefully. To reduce the risk of fire, electrical shock or injury when using the appliance, follow basic precautions, including the following:



- Plug into a grounded 3-prong outlet, do not remove grounding prong, do not use an adapter, and do not use an extension cord.
- Replace all panels before operating.
- It is recommended that a separate circuit serving only your appliance be provided. Use receptacles that cannot be turned off by a switch or pull chain.
- Never clean appliance parts with flammable fluids. These fumes can create a fire hazard or explosion.
- Do not store or use gasoline or other flammable vapors and liquids in the vicinity of this or any other appliance. The fumes can create a fire hazard or explosion.
- Before proceeding with cleaning and maintenance operations, make sure the power line of the unit is disconnected.
- Do not connect or disconnect the electric plug when your hands are wet.
- Unplug the appliance or disconnect power before cleaning or servicing. Failure to do so can result in electrical shock or death.

- Do not attempt to repair or replace any part of your appliance unless it is specifically recommended in this manual. All other servicing should be referred to a qualified technician.

WARNING

FOLLOW WARNING CALLOUTS BELOW ONLY WHEN APPLICABLE TO YOUR MODEL

- Use two or more people to move and install appliance. Failure to do so can result in back or other injury.
- To ensure proper ventilation for your appliance, the front of the unit must be completely unobstructed. Choose a well-ventilated area with temperatures above 60°F (16°C) and below 90°F (32°C). This unit must be installed in an area protected from the elements, such as wind, rain, water spray or drips.
- The appliance should not be located next to ovens, grills or other sources of high heat.
- The appliance must be installed with all electrical, water and drain connections in accordance with state and local codes. A standard electrical supply (115 V AC only, 60 Hz), properly grounded in accordance with the National Electrical Code and local codes and ordinances, is required.
- Do not kink or pinch the power supply cord of the appliance.
- The size of the fuse (or circuit breaker) should be 15 amperes.
- It is important that the appliance be leveled in order to work properly. You may need to make several adjustments to level it.
- All installations must be in accordance with local plumbing code requirements.
- Make certain that the pipes are not pinched, kinked or damaged during installation.
- Check for leaks after connection.
- Never allow children to operate, play with or crawl inside the appliance.
- Although the unit has been tested at the factory, due to long-term transit and storage, the first batch of cubes must be discarded.
- Do not use solvent-based cleaning agents or abrasives on the interior. These cleaners may damage or discolor the interior.
- Use this appliance only for its intended purpose as described in this *Instruction Manual*.
- Keep fingers out of the “pinch point” areas. Clearances between the door and cabinet are necessarily small. Be careful closing doors when children are in the area.

DANGER

Risk of child entrapment!

Child entrapment and suffocation are not problems of the past. Junked or abandoned appliances are still dangerous, even if they will “just sit in the garage a few days”.

Before discarding your old refrigerator:

- *Take off the doors*
- *Leave the shelves in place so that children may not easily climb inside.*

- SAVE THESE INSTRUCTIONS -

LOCATION OF PARTS

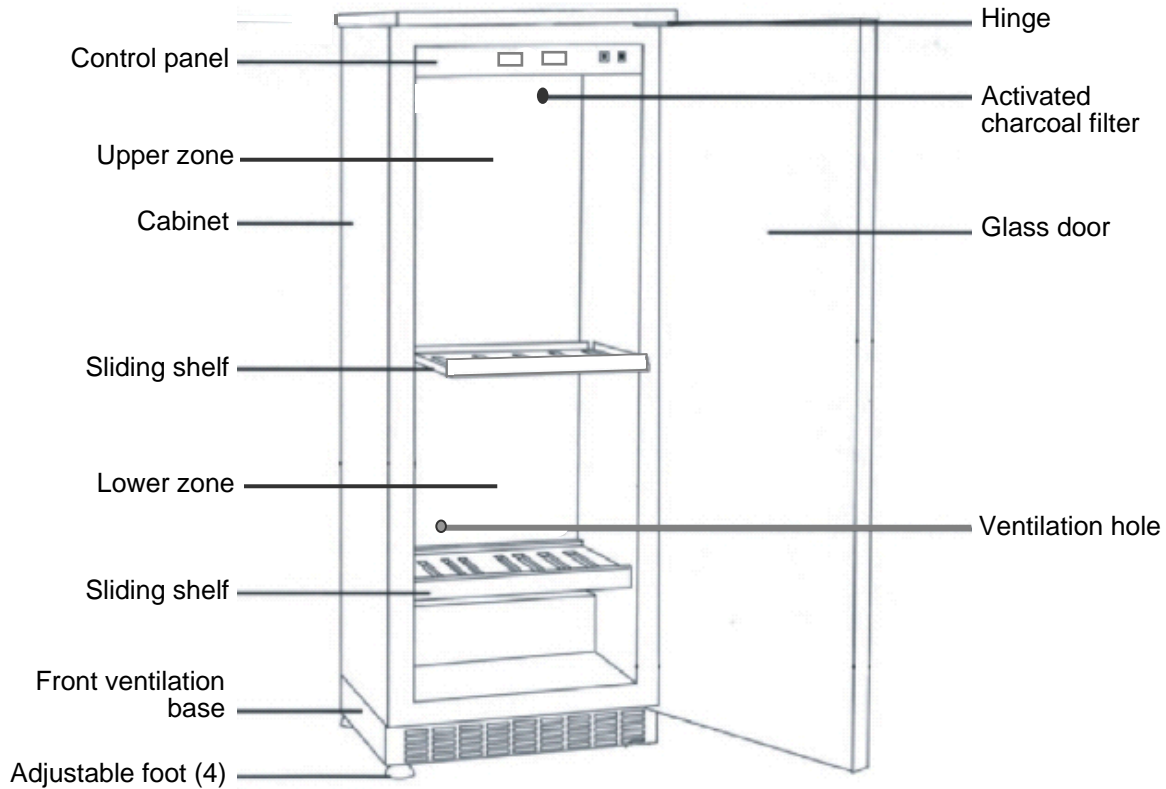

INSTALLATION INSTRUCTIONS

BEFORE USING YOUR APPLIANCE

- Remove the exterior and interior packing.
- Before connecting the appliance to the power source, let it stand upright for approximately 2 hours. This will reduce the possibility of a malfunction in the cooling system from handling during transportation.
- Clean the interior surface with lukewarm water using a soft cloth.
- Install the handle on the door if it is not already in place (see page 7).

INSTALLATION OF YOUR APPLIANCE

- The appliance is designed for free-standing installation.
- **WARNING:** Do not store or install the appliance outdoors.
- **CAUTION:** This appliance is designed for storing and cooling wines. Do not store perishable food, medicine or other medical products.
- Place your Wine Cellar on a floor that is strong enough to support it when it is fully loaded. To level the unit, adjust the four leveling legs. (It is advisable to use a carpenter's level.)
- Leave at least 2 inches of space around the back and sides of the unit, and 1 inch on top, to allow proper air circulation to cool the compressor and condenser. Take care that the air vent at the front of

the appliance is never covered or blocked in any way.

- Do not install the appliance near an oven, radiator or other heating source. Direct sunlight may affect the acrylic coating and heat sources may increase electrical consumption. Do not install in a location where the temperature will fall below 60°F (16°C). For best performance, do not install the appliance behind a cabinet door or block the base grille.
- Avoid locating the unit in a moist area (laundry room, utility room, bathroom, etc.).
- Making sure that the ON/OFF Key at the right side of the control panel is in the OFF position, plug the Wine Cellar into an exclusive, properly grounded wall outlet.
- Remove the protective paper from the charcoal filter that you will find in the accessories pack. Position the filter in the round box located in the upper rear wall of the cabinet.
- Wait 48 hours before switching the appliance ON so as to allow refrigeration fluids to settle.

ELECTRICAL CONNECTION



WARNING

Improper use of the grounded plug can result in the risk of electrical shock. If the power cord is damaged, have it replaced by a qualified electrician or an authorized service center.

This appliance should be properly grounded for your safety. The power cord of this appliance is equipped with a three-prong plug which mates with standard three-prong wall outlets to minimize the possibility of electrical shock.

Do not under any circumstances cut or remove the third (ground) prong from the power cord supplied. For personal safety, this appliance must be properly grounded.

This appliance requires a standard 115/120 Volt AC ~ 60Hz, three-prong grounded electrical outlet. Have the wall outlet and circuit checked by a qualified electrician to make sure the outlet is properly grounded. When a standard 2-prong wall outlet is encountered, it is your responsibility and obligation to have it replaced with a properly grounded 3-prong wall outlet.

To prevent accidental injury, the cord should be secured behind the appliance and not left exposed or dangling.

The appliance should always be plugged into its own individual electrical outlet which has a voltage rating that matches the rating label on the appliance. This provides the best performance and also prevents overloading house wiring circuits that could cause a fire hazard from overheating. Never unplug the appliance by pulling on the power cord. Always grip the plug firmly and pull straight out from the receptacle. Repair or replace immediately all power cords that have become frayed or otherwise damaged. Do not use a cord that shows cracks or abrasion damage along its length or at either end. When moving the appliance, be careful not to damage the power cord.

Any questions concerning power and/or grounding should be directed toward a certified electrician or an authorized service center.

EXTENSION CORD

Because of potential safety hazards under certain conditions, it is strongly recommended that you do not use an extension cord with this appliance. However, if you must use an extension cord, it is absolutely necessary that it be a UL/CUL-Listed, 3-wire grounding type appliance extension cord having a grounding type plug and outlet and that the electrical rating of the cord be 115 volts and at least 10 amperes.

INSTALLING THE STAINLESS STEEL HANDLE

This wine cellar includes a stainless steel handle that is not required to operate the unit. To install the handle (if not already installed), follow the instructions below:

1. Pull away the door gasket in the area where the handle is to be installed. The gasket is easily displaced by hand; no tools are necessary.
2. Using a flathead screwdriver, remove the two (2) pre-installed decorative plugs from the back of the door. Save the decorative plugs for future use.
3. Insert the two (2) Phillips head handle screws with the lock washers and flat washers through the gasket side of the door frame until the screws pass through the door frame. Follow the sequence shown in the figure.
4. Align the handle with the screws installed in step # 3 above. Tighten the screws using a Phillips head screwdriver until the handle is both flush and secured tightly against the door frame. (DO NOT over-tighten as this will cause damage to the handle assembly.)
5. Replace the door gasket to its original position.

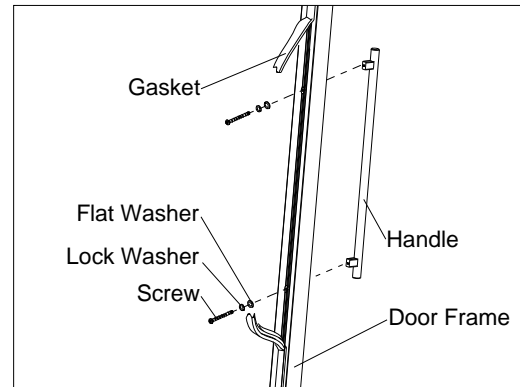

OPERATING YOUR APPLIANCE

It is recommended you install the appliance in a place where the ambient temperature is between 72° and 78°F (23°-26°C). If the ambient temperature is above or below the recommended temperatures, the performance of the unit may be affected. For example, placing your unit in extreme cold or hot conditions may cause interior temperatures to fluctuate. The range of 40°-72°F (5°-22°C) may not be reached.

NOTE:

If the unit is unplugged, or power is lost or turned off, you must wait at least 5 minutes before restarting the unit. If you attempt to restart before this time delay, the unit will not start.

The SWC1545 defrosts itself automatically.

RECOMMENDED TEMPERATURE SETTINGS

Conservation	49 ~ 57°F	10 ~ 14°C
Red Wines	58 ~ 72°F	15 ~ 22°C
Dry/White Wines	48 ~ 57°F	9 ~ 14°C
Rosé Wines	49 ~ 51°F	10 ~ 11°C
Sparkling Wines	40 ~ 47°F	5 ~ 8°C

CONTROL PANEL

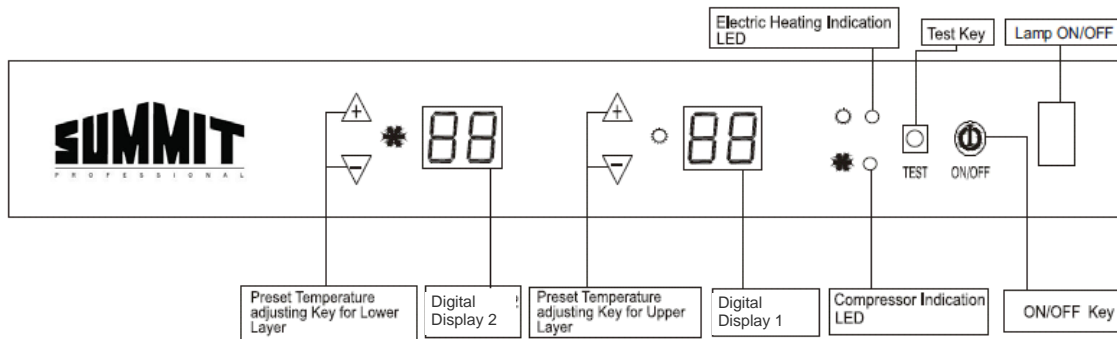

ON/OFF Key turns the wine cellar on and off. It should be in the OFF position when the unit is being plugged in to a power source or disconnected from that source.

Digital Display 1 shows the current temperature or preset temperature of the upper zone of the cabinet. When the **+/- Key** is pressed, the display flashes, indicating the preset temperature. If no temperature setting operation occurs within five seconds, the system will automatically return to the display of ambient temperature in the storage cabinet.

Preset Temperature Adjusting Key (+/-) for Upper Zone: Press this key to adjust the preset temperature of the upper zone. Every time it is pressed, the preset temperature of the upper zone is increased or decreased by 1 degree. The temperature setting range for the upper zone is 54°F to 72°F (12°C to 22°C).

Digital Display 2 shows the current temperature or preset temperature of the lower zone of the cabinet. When the **+/- Key** is pressed, the display flashes, indicating the preset temperature. If no temperature setting operation occurs within five seconds, the system will automatically return to the display of ambient temperature in the storage cabinet.

Preset Temperature Adjusting Key (+/-) for Lower Zone: Press this key to adjust the preset temperature of the lower zone. Every time it is pressed, the preset temperature of the lower zone is increased or decreased by 1 degree. The temperature setting range for the lower zone is 41°F to 54°F (5°C to 12°C).

Lamp ON/OFF: This switch is controlled by the opening and closing of the door.

Compressor Indicator: This LED is lit while the compressor is running and goes out when the compressor turns off.

Electric Heating Indicator: This LED is lit during operation of the electric heating device and goes out when the device stops operating.

Test Key: If this key is pressed in Standby mode, the compressor and electric heating device will operate at the same time, and the Compressor Indicator and Electric Heating Indicator LEDs will turn on simultaneously. When this key is released, the system returns to the previous Standby state. The Test Key is invalid when the appliance is operating.

SETTING THE TEMPERATURE CONTROLS

- The temperature-setting ranges of the upper zone (54°F to 72°F, or 12°C to 22°C) and lower zone (41°F to 54°F, or 5°C to 12°C) are effective when the ambient temperature is less than or equal to 90°F, or 32°C. At temperatures higher than this, it would be difficult to reach the lowest temperature settings of the upper and lower zones.
- The temperature difference displayed on Digital Displays 1 and 2 should be about 9 Fahrenheit degrees (or 5 Celsius degrees).
- Digital Displays 1 and 2 have the capability of showing temperatures from 32°F to 99°F (0°C to 37°C). When the temperature in the storage cabinet is below 32°F (0°C), the display will show 000, and when the temperature in the cabinet is above 99°F (37°C), the display will show 99°F (37°C).
- The difference between the displayed temperature and the set temperature is $\pm 3^\circ\text{F}$ ($\pm 1.5^\circ\text{C}$) once the cabinet temperature has reached equilibrium.

WINE SHELVES

To prevent damaging the door gasket, make sure to have the door all the way open when pulling the shelves out of the rail compartment.

STORAGE

Bottles can differ in size and shape. As such the actual number of bottles you may be able to store can vary. Bottle capacity is at its optimum when storing traditional 750-ml Bordeaux bottles.

We recommend that you observe the tips below to optimize loading:

- Spread your bottles out as evenly as possible over the shelves so that weight is not concentrated in one point. Bottles should not all be grouped together at the top or bottom of the cabinet.
- Make sure your bottles do not touch the back of the cabinet or the step at the bottom.
- Do not stack bottles on a sliding shelf.
- Never try to pull out more than one sliding shelf at a time.

Typical layouts:



NOTE: Do not let bottles touch the rear wall of the cabinet. Bottles stored with their bottom surfaces facing front can rest on the front edge of the wooden shelf, as shown in the illustration at the right.

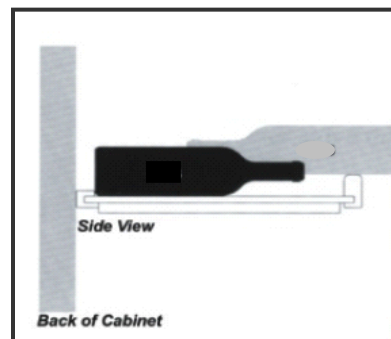

DOOR LOCK

Your unit is provided with a lock and key combination. The keys are located inside the plastic bag that contains the *Instruction Manual*. Insert the key into the lock and turn it clockwise to lock the door, making sure the metal bracket is engaged completely. To unlock the door, reverse the operation. Remove the key and place it in a secure place for safekeeping.

OPERATING PROBLEMS

START-UP

Compressor does not start even though the desired temperature is lower than the temperature in the room.

1. Check the wall socket by plugging in any type of electrical device.
2. Plug in the wine cellar.
3. Press the TEST button and check that the red and green indicator LEDs light up (in Standby mode).
4. If the compressor still does not start up, call for service.

Compressor does not stop.

1. Place your hand on the condenser (metal screen at the back of the cabinet) to check its temperature. Call for service if it is cold.
2. If the condenser is hot, set the cold temperature as high as possible and make sure the compressor indicator goes off. If the compressor does not stop, unplug the appliance and call for service.

DURING OPERATION

The Digital Display shows a temperature lower than the temperature you set.

1. Check the temperature set points.
2. Check that the red Electric Heating LED is on.
3. Press the TEST button and check that the red and green indicator lights on the right side of the control panel are on. If not, call for service.

The Digital Display shows a temperature higher than the temperature you set.

1. Check the temperature set points.
2. Check that the green Compressor LED is on.
3. Press the TEST button and check that the red and green indicator lights on the right side of the control panel are on. If not, call for service.

NOTE: The wine cellar must only be serviced by a qualified refrigeration technician, who must check the circuit for leaks before putting the unit back into service. Any servicing of the electrical circuit must only be performed by a qualified electrician.

Whatever the case, if your appliance does not seem to be operating normally, unplug it and call for service. SUMMIT's Customer Help number is **1-800-932-4267**.

CARE AND MAINTENANCE

ROUTINE MAINTENANCE

Your wine cellar is easy to operate and has proven its reliability. It will provide long-lasting satisfaction if you follow the simple maintenance and cleaning operations listed below.

- Replace the activated charcoal filter in the cabinet's upper ventilation hole every six months. These filters are available from SUMMIT through our website, www.summitappliance.com/support, or by calling Customer Service at **1-800-932-4267**.
- Remove dust from the condenser (metal screen on the back of the cabinet) twice a year.
- Make sure the power cord is unplugged before cleaning the back of your cabinet, or before moving it.
- Clean the inside of the cabinet thoroughly once a year, after unplugging and unloading it. Use water and a mild detergent, then rinse carefully and dry.
- Wash the outside cabinet with warm water and mild liquid detergent. Rinse well and wipe dry with a clean soft cloth.
- Do not use steel wool or a steel brush on the stainless steel door frame or handle.

CAUTION:

Failure to unplug the appliance during cleaning could result in electrical shock or other personal injury.

POWER FAILURE

Most power failures are corrected within a few hours and should not affect the temperature of your appliance if you minimize the number of times the door is opened. If the power is going to be off for a longer period of time, you need to take the proper steps to protect the contents.

VACATION TIME

- **Short vacations:** Leave the appliance operating during vacations of less than three weeks.
- **Long vacations:** If the appliance will not be used for several months, remove all items and turn off the appliance. Clean and dry the interior thoroughly. To prevent odor and mold growth, leave the door open slightly, blocking it open if necessary.

MOVING YOUR APPLIANCE

1. Remove all items.
2. Securely tape down all loose items (shelves) inside your appliance.
3. Turn the adjustable legs up to the base to avoid damage.
4. Tape the door shut.
5. Be sure the appliance stays secure in the upright position during transportation. Also, protect the outside of the appliance with a blanket or similar item.

ENERGY-SAVING TIPS

- The appliance should be located in the coolest area of the room, away from heat producing appliances and out of direct sunlight.
- Ensure that the unit is adequately ventilated. Never cover air vents.
- Do not keep the door open any longer than necessary.

TROUBLESHOOTING

You can solve many common problems easily, saving you the cost of a possible service call. Try the suggestions below to see if you can solve the problem before calling the servicer.

Troubleshooting Guide

PROBLEM	POSSIBLE CAUSE
The unit does not operate.	Not plugged in. The appliance is turned off. Tripped circuit breaker or blown fuse.
The unit is not cold enough.	Check the temperature control setting. External environment may require a higher setting. The door is opened too often. The door is not closed completely. The door gasket does not seal properly.
Turns on and off frequently.	The room temperature is warmer than normal. A large amount of contents has been added to the wine cellar. The door is opened too often. The door is not closed completely. The temperature control is not set correctly. The door gasket does not seal properly.
The light does not work.	Not plugged in. Tripped circuit breaker or blown fuse.
Vibrations	Check to assure that the appliance is level.
The unit seems to make too much noise.	The rattling or gurgling noise may come from the flow of the refrigerant, which is normal. Contraction and expansion of the inside walls may cause popping and crackling noises. The appliance is not level.
The door will not close properly.	The appliance is not level. The gasket is dirty. The shelves are out of position.
Display shows E2 (E3) . Buzzer sounds.	The temperature sensor for the upper (lower) zone has failed. The sensor is experiencing either a short circuit or an open circuit. Call for service*.
Display shows E9 . Buzzer sounds.	The upper zone is not cooling properly. If display message does not return to normal temperature reading within an hour or two, call for service*.
Display shows E8 . Buzzer sounds.	The lower zone is becoming too cold. If display message does not return to normal temperature reading within an hour or two, call for service*.

* Call SUMMIT Customer Service at **1-800-932-4267** weekdays between 8:00AM and 5:00PM (ET).

LIMITED WARRANTY

ONE-YEAR LIMITED WARRANTY

Within the 48 contiguous United States, for one year from the date of purchase, when this appliance is operated and maintained according to instructions attached to or furnished with the product, warrantor will pay for factory-specified parts and repair labor to correct defects in materials or workmanship. Service must be provided by a designated service company. Outside the 48 states, all parts are warranted for one year from manufacturing defects. Plastic parts, shelves and cabinets are warranted to be manufactured to commercially acceptable standards, and are not covered from damage during handling or breakage.

5-YEAR COMPRESSOR WARRANTY

1. The compressor is covered for 5 years.
2. Replacement does not include labor.

ITEMS WARRANTOR WILL NOT PAY FOR:

1. Service calls to correct the installation of your appliance, to instruct you how to use your appliance, to replace or repair fuses or to correct wiring or plumbing.
2. Service calls to repair or replace appliance light bulbs or broken shelves. Consumable parts (such as filters) are excluded from warranty coverage.
3. Damage resulting from accident, alteration, misuse, abuse, fire, flood, acts of God, improper installation, installation not in accordance with electrical or plumbing codes, or use of products not approved by warrantor.
4. Replacement parts or repair labor costs for units operated outside the United States.
5. Repairs to parts or systems resulting from unauthorized modifications made to the appliance.
6. Expenses for travel and transportation for product service in remote locations.
7. The removal and reinstallation of your appliance if it is installed in an inaccessible location or is not installed in accordance with published installation instructions.

DISCLAIMER OF IMPLIED WARRANTIES – LIMITATION OF REMEDIES

CUSTOMER'S SOLE AND EXCLUSIVE REMEDY UNDER THIS LIMITED WARRANTY SHALL BE PRODUCT REPAIR AS PROVIDED HEREIN. IMPLIED WARRANTIES, INCLUDING WARRANTIES OF MERCHANTABILITY OR FITNESS FOR A PARTICULAR PURPOSE, ARE LIMITED TO ONE YEAR. WARRANTOR SHALL NOT BE LIABLE FOR INCIDENTAL OR CONSEQUENTIAL DAMAGES. SOME STATES DO NOT ALLOW THE EXCLUSION OR LIMITATION OF INCIDENTAL OR CONSEQUENTIAL DAMAGES, OR LIMITATIONS ON THE DURATION OF IMPLIED WARRANTIES OF MERCHANTABILITY OR FITNESS, SO THESE EXCLUSIONS OR LIMITATIONS MAY NOT APPLY TO YOU. THIS WARRANTY GIVES YOU SPECIFIC LEGAL RIGHTS AND YOU MAY ALSO HAVE OTHER RIGHTS, WHICH VARY FROM STATE TO STATE.

WARNING! This product may contain chemicals known to the state of California to cause cancer or birth defects or other reproductive harm. For more information, visit: www.summitappliance.com/prop65

Chemicals known by the manufacturer to be present in this product in concentrations higher than threshold limits: NONE.

FELIX STORCH, INC.
770 Garrison Avenue
Bronx, NY 10474
Phone: (718) 893-3900
Fax: (718) 842-3093
www.summitappliance.com



For parts and accessory ordering,
troubleshooting and helpful hints, visit:
www.summitapplianceparts.com