



## REFRIGERATOR-FREEZER

### Model CP35



### *Instruction Manual*

BEFORE USE, PLEASE READ AND FOLLOW ALL SAFETY RULES AND OPERATING INSTRUCTIONS.

Keep proof of original sales date (such as your sales slip) with this manual to establish the warranty period.

*Write down the serial number here. You'll find it on a plate located either on the back of the appliance or on an interior wall.*

\_\_\_\_\_

**FELIX STORCH, INC.**

**770 Garrison Avenue**

**Bronx, New York 10474**

**[www.summitappliance.com](http://www.summitappliance.com)**

# Table of Contents

<b>Important Safeguards</b> .....	<b>2 – 3</b>
<b>Introduction</b> .....	<b>4</b>
<b>Installation</b> .....	<b>4 – 7</b>
<i>Before using your appliance</i> .....	4
<i>Installing your appliance</i> .....	4 – 5
<i>Electrical connection</i> .....	5
<i>Test run</i> .....	5 – 6
<i>Reversing the door swing</i> .....	6 – 7
<b>Operation</b> .....	<b>8 – 9</b>
<i>Temperature control</i> .....	8
<i>Storing fresh foods</i> .....	8 – 9
<i>Storing food in the freezer compartment</i> .....	9
<i>Defrosting</i> .....	9
<b>Care and Maintenance</b> .....	<b>10 – 11</b>
<i>Cleaning the appliance</i> .....	10
<i>Switching off the appliance when not in use</i> .....	10
<i>Disposing of a worn-out appliance</i> .....	10
<i>Energy-saving tips</i> .....	10 – 11
<b>Troubleshooting</b> .....	<b>12 – 13</b>
<b>Limited Warranty</b> .....	<b>15</b>

## IMPORTANT SAFEGUARDS

Before the refrigerator/freezer is used, it must be properly positioned and installed as described in this manual, so read the manual carefully. To reduce the risk of fire, electrical shock or injury when using this appliance, follow basic precautions, including the following:



- Plug into a grounded 3-prong outlet, do not remove grounding prong, do not use an adaptor and do not use an extension cord.
- It is recommended that a separate circuit, serving only your refrigerator, be provided. Use receptacles that cannot be turned off by a switch or pull chain.
- Never clean refrigerator parts with flammable fluids. These fumes can create a fire hazard or explosion. Also, do not store or use gasoline or other flammable vapors and liquids in the vicinity of this or any other appliance. The fumes can create a fire hazard or explosion.
- Before proceeding with cleaning and maintenance operations, unplug the appliance or disconnect power. Failure to do so can result in electrical shock or death.
- Do not connect or disconnect the electric plug when your hands are wet.
- Do not attempt to repair or replace any part of your appliance unless it is specifically recommended in this manual. All other servicing should be referred to a qualified technician.
- ***DANGER: Risk of child entrapment!***  
Child entrapment and suffocation are not problems of the past. Junked or abandoned appliances are still dangerous, even if they will "just sit in the garage a few days."
  - ✓ Before you throw away your old refrigerator or freezer, take off the doors. Leave the shelves in place so that children may not easily climb inside.
  - ✓ Never allow children to operate, play with or crawl inside the refrigerator.

## **WARNING**

- **This unit is not designed to operate in enclosed spaces. When placing your unit, make sure you allow at least 4” of clearance on all sides.**
- Use two or more people to move and install the appliance. Failure to do so can result in back or other injury. When moving the appliance, do not tilt it beyond 45° from the upright position.
- To ensure proper ventilation for your refrigerator-freezer, the front of the unit must be completely unobstructed. Choose a well-ventilated area with temperatures above 60°F (16°C) and below 90°F (32°C). This unit must be installed in an area protected from the elements such as wind, rain, water spray or drips.
- The appliance should not be located next to ovens, grills or other sources of high heat.
- The appliance must be installed with an electrical connection in accordance with state and local codes. A standard electrical supply (115-120V AC only, 60 Hz), properly grounded in accordance with the National Electrical Code and local codes and ordinances is required.
- Do not kink or pinch the power supply cord of the appliance.
- The fuse (or circuit breaker) size should be 15 amps.
- It is important for the refrigerator-freezer to be leveled in order to work properly. You may need to make several adjustments to level it.
- Do not use solvent-based cleaning agents or abrasives on the interior surfaces. These cleaners may damage or discolor the interior.
- This appliance is not intended for use by young children or infirm persons without supervision.
- Do not use this apparatus for other than its intended purpose.

**CAUTION: THIS APPLIANCE IS NOT DESIGNED FOR THE STORAGE OF MEDICINE OR OTHER MEDICAL PRODUCTS.**

***SAVE THESE INSTRUCTIONS***

## Introduction

The CP35 is a unique two-door refrigerator with a zero degree freezer. The fresh food section is automatically defrosted; the freezer is manually defrosted. The refrigerator compartment stores fresh foods at temperatures of 34°F (1°C) and higher while the freezer maintains a temperature of 0°F (-17°C).

This appliance is available in White (CP-35) and Black (CP-35B). To include a double lock, add the suffix LL to the model number.

**These products are not designed to operate in enclosed spaces. When placing your unit, make sure you allow at least 4” of clearance on all sides.**

## Installation

### Before Using Your Appliance

1. Remove the exterior and interior packing. To remove any remaining tape or glue, rub the area briskly with your thumb. Tape or glue residue can also be easily removed by rubbing a small amount of liquid dish soap over the adhesive with your fingers. Wipe with warm water and dry.  
Do not use sharp instruments, rubbing alcohol, flammable fluid or abrasive cleaners to remove tape or glue. These products can damage the surface of your refrigerator.
2. When moving the appliance, do not tilt it more than 45° from the upright position.
3. Before connecting the appliance to the power source, let it stand upright for approximately 2 hours. This will reduce the possibility of a malfunction in the cooling system from handling during transportation.
4. Clean the interior surfaces with lukewarm water using a soft cloth.

### Installing Your Appliance

*WARNING: Keep flammable materials and vapors such as gasoline away from the refrigerator.*

- Place your appliance on a floor that is strong enough to support it when fully loaded. To level your appliance, adjust the leg at the front of the appliance.
- To ensure proper ventilation for your refrigerator-freezer, leave at least 4" of space on each side, 4" at the back and 4" above the unit.
- If you are installing the appliance next to a fixed wall, leave sufficient space on the hinge side to allow for the door to swing open.
- Locate the appliance away from direct sunlight and sources of heat (stove, heater, radiator, etc.). Direct sunlight can affect the refrigerator's coating and

heat sources can increase electrical consumption. Extremely cold ambient temperatures may also cause the appliance to perform improperly.

- Avoid locating the appliance in moist areas. Too much moisture in the air will cause frost to form quickly on the evaporator, requiring more frequent defrosting of the appliance.

### **Electrical Connection**

#### **⚡ Warning ⚡**

Improper use of the grounded plug can result in the risk of electrical shock. If the power cord is damaged, have it replaced by an authorized service technician.

- This appliance should be properly grounded for your safety. The power cord of this appliance is equipped with a three-prong plug which mates with standard three-prong wall outlets to minimize the possibility of electrical shock.
- Do not under any circumstances cut or remove the third ground prong from the power cord supplied.
- Plug the appliance into an exclusive, properly installed grounded wall outlet. Any questions regarding power and/or grounding should be directed toward a certified electrician or an authorized Summit service center.
- It is recommended that a separate circuit serving only this appliance be provided. Use a receptacle that cannot be turned off with a switch or pull chain.
- Do not use an extension cord.
- This appliance requires a standard 115/120-volt, 60 Hz electrical outlet with three-prong ground and a 15-amp fuse. To prevent accidental injury, the power cord should be secured behind the appliance and not left exposed or dangling.

NOTE: Before performing any type of installation, cleaning or removing a light bulb, turn the temperature control to **OFF** and then disconnect the unit from the electrical power source. When you are finished, reconnect the refrigerator to the power source and reset the temperature control to the desired setting.

### **Test Run**

Before using your appliance, make a test run to be sure it is in working order. If not, check the electrical supply. When the cause of trouble cannot be located, contact Summit Customer Service at **1-800-932-4267**.

1. Set the temperature control knob to **OFF** and then plug the AC cord into an electrical outlet of 115 volts, 60Hz. The motor should not run.
2. Set the knob to **MAX** and let the refrigerator operate for 20 minutes. The freezer compartment should get slightly frosted and the motor should run smoothly with a soft hum.

3. Then rotate the knob counter-clockwise toward **MIN**. Before the pointer of the knob reaches **MIN**, the motor should turn off.

### **Reversing the Door Swing**

This appliance has the capability of the doors opening from either the left or the right side. The unit is delivered to you with the doors opening from the left side. Should you desire to reverse the opening direction, follow the directions and diagram below. The numbers in the diagram indicate the procedure order in the instructions. If you have a problem, call Customer Service at **1-800-932-4267**.

1. Remove the hinge cap by twisting it off.
2. Remove the upper hexagonal head screws. The top hinge and the freezer door can now be removed.
3. Remove the middle hexagonal head screws. The middle hinge and the refrigerator door can now be removed.
4. Remove the cover for middle hinge holes and re-attach it symmetrically to the holes on the other side.
5. Tilt the refrigerator back or lay it on its back for steps 6, 7, and 8. Use a pad or blanket to protect the floor and to avoid scratching the painted finish.
6. Remove the leveling legs by turning them counterclockwise. Remove the lower hexagonal head screws, two on the hinge side and one near the front corner of the other side.
7. Attach the bottom hinge symmetrically to the other side of the cabinet with the screws removed in procedure 6. (Do not tighten the screws completely.)
8. Attach the left side leg and the leg spacer to the other side hole which was positioned symmetrically.
9. Remove the upper hinge plastic pins and insert them in the holes from which the screws were removed in step 2.
10. Take off the hinge collar caps from both the Freezer and the Refrigerator doors using a screwdriver and insert them in the hinge collars on the opposite side.
11. Attach the shaft to the hinge bottom. Attach the refrigerator door to the shaft.
12. Rotate the middle hinge 180°. Attach it to the refrigerator door and secure it with screws. (Do not tighten the screws completely.)
13. Attach the upper hinge to the freezer door. Attach the freezer door to the middle hinge and use the screws to attach the upper hinge. (Do not tighten the screws completely.)
14. The direction in which the door opens has now been changed; however, the following points should be checked:
  - a. The door is on straight.
  - b. There is no space between the door gasket and the refrigerator unit itself when the door is closed.
  - c. The gasket on the hinge side is not caught between the door and the unit

when the door is opened or closed. (If the door is forced closed when the gasket is caught, the gasket may be damaged.)

When checking the above points, if you discover that the door is not installed properly (this is apt to happen on the first try), loosen the screws holding the upper hinge, straighten the door and tighten the screws slowly with the socket wrench. After making sure that the door is installed correctly, tighten all the screws holding the hinge. If they are not tightened, the door may slip out of position or there may be an opening between the door and the unit.

15. Stand the unit back in the upright position.

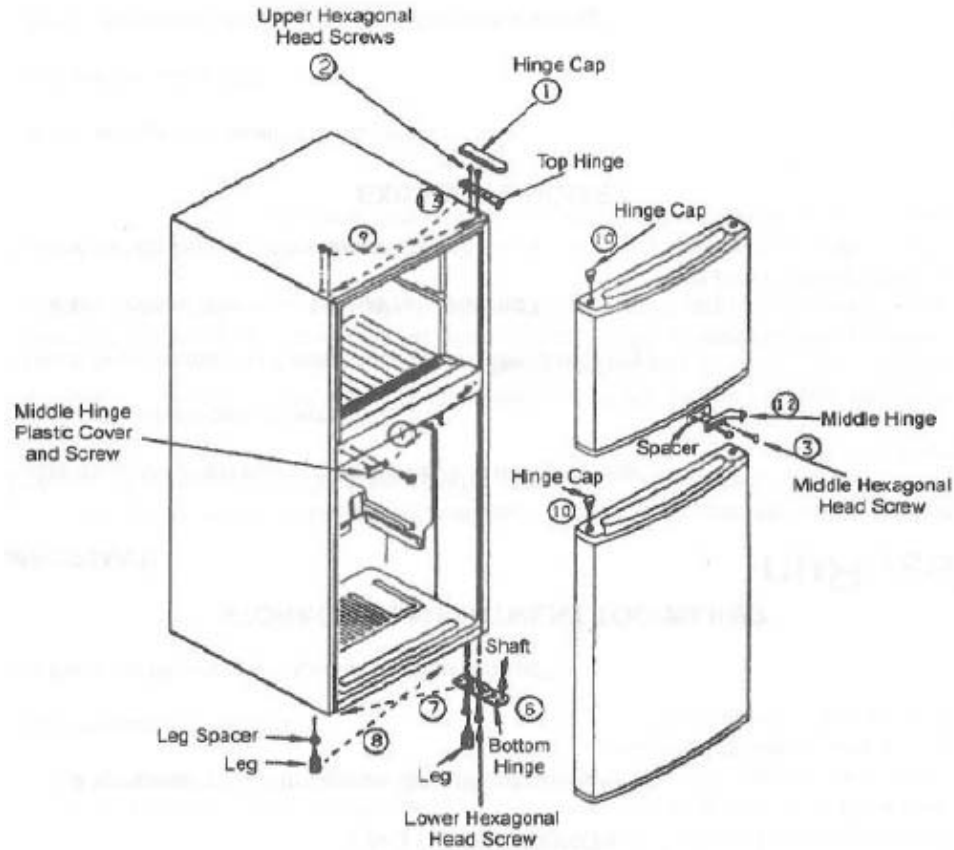



## Operation

### Temperature Control

The temperature inside the refrigerator compartment is controlled by turning the thermostat dial. Higher numbers mean greater cooling power; lower numbers mean less cooling power.

Set the temperature control dial to **3** for optimum refrigeration/freezing conditions under normal circumstances. Set the dial to **MAX** only when rapid refrigeration/freezing in your appliance is necessary.

Be sure to set the dial back to **3** later on.

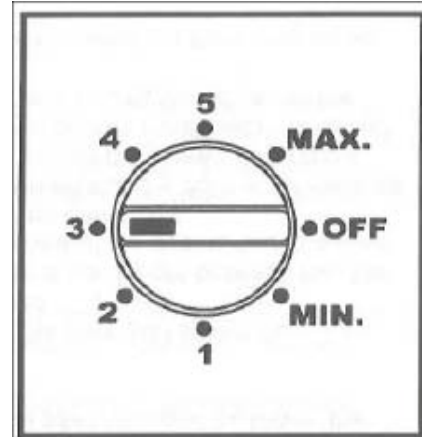

#### IMPORTANT:

- Do not operate your refrigerator for more than six hours with the temperature control dial set to **5** or **MAX**. At these settings, the compressor will run continuously. Consequently, foodstuffs stored in the refrigerator compartment will be frozen and frost will form on the cooling unit (evaporator).
- When the room temperature is below 60°F, set the temperature control dial to **2**.
- At the control dial setting of **1**, the temperature in the freezer compartment will not remain sufficiently low for ice cream and frozen foods.
- If the unit is turned off or unplugged, **YOU MUST ALLOW THREE (3) MINUTES BEFORE RESTARTING OR REPLUGGING THE UNIT**. The unit will not start if you attempt to restart it in less than three (3) minutes.

### Storing Fresh Foods

- Foods to be stored in the refrigerator should be properly packed to prevent loss of moisture and mixing of odors. Use plastic bags or wrap, aluminum foil, wax paper, covered containers or bottles.
- Never store any inflammable, volatile or explosive substances.
- Beverages with a high percentage of alcohol should be stored in tightly sealed bottles in a vertical position.
- Stored items should not touch the rear wall of the refrigerator.
- Some organic substances like the volatile oils in lemon and orange peel, the acid in butter, etc., can cause damage when in contact with plastic surfaces or gaskets for a long period of time.
- An unpleasant odor inside the refrigerator is a sign that something is wrong with the food or that your refrigerator needs cleaning. Odors may be eliminated or reduced by washing the interior of the refrigerator with a mild solution of water and vinegar.

- If you plan on taking a long trip, make sure you remove all perishable food before you leave to prevent any odors.

### **Storing Food in the Freezer Compartment**

- Only freeze fresh, high-quality products. Meat, poultry, fish, vegetables, fruit, dairy products and ready-made meals are suitable for freezing. Items with a high water content, e.g. lettuce, radishes, grapes, apples, pears and cucumbers, are not suitable for freezing.
- Pack items to be frozen in airtight containers, freezer bags or the like. Freeze items in suitable portions. Do not freeze vegetables in portions larger than 5½ lbs. Do not freeze meat in portions larger than 5½ lbs. Keep packages dry to prevent them from freezing together. To ensure rapid freezing, make sure, as far as possible, that items placed in the freezer are not touching. Ensure that there is as little air in the packages as possible to prevent the surfaces of the items from drying out.
- Always remember to write the date, content and quantity on the packages before placing them in the freezer.

### **Defrosting**

#### **Refrigerator compartment:**

The cooling unit (evaporator) in the refrigerator compartment is automatically defrosted whenever the compressor motor stops running. No manual defrosting is required. Frost may grow thick temporarily if the room temperature is high or the door is opened frequently. Under normal conditions, however, it will disappear after a period of operation.

#### **Freezer compartment:**

The freezer compartment should be kept free of frost for good freezing and economical operation at low power consumption. Frost should not be allowed to grow thicker than 1/8" to 1/4".

- Scrape frost off the freezer compartment walls with the scraper supplied with your refrigerator. This can be done without stopping operation.
- After a long period of operation, frost in the freezer compartment may become too hard to be removed with the scraper. In this case, set the temperature control dial to **OFF**, leave the freezer compartment door open for several minutes, and wipe the freezer compartment walls clean of frost with a hot towel. Afterwards, wipe the walls dry and reset the control dial.

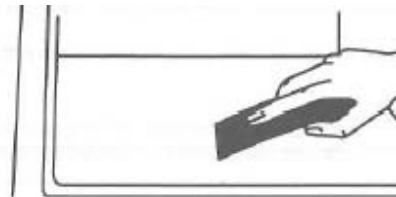

## Care and Maintenance

### Cleaning the Appliance

**Disconnect the power supply** before cleaning the appliance. To avoid damaging the surfaces, do not use coarse or abrasive cleaning agents.

- Clean the **exterior** with water and detergent. Varnished surfaces can be cleaned with a soft cloth and an alcohol-based cleaning agent (for example, glass cleaners). You may also use alcohol (ethanol or isopropyl alcohol). The application of harsh and abrasive products such as stainless steel cleaners is not appropriate for the cleaning of plastic and coated parts.
- Remove the detachable accessories in the interior of the appliance and clean it with a solution of water and liquid detergent. Plastic parts **cannot** be washed in a dishwasher.
- Wash the interior of the appliance with lukewarm water to which you have added one or two spoonfuls of vinegar.
- Every now and then wipe the condenser on the rear wall with a soft non-metal brush, or use a vacuum cleaner.
- Do not forget to clean the defrost water receptacle above the refrigerator's compressor (do not remove the receptacle).
- After cleaning, connect the appliance to the power supply and reload the packages.

### Switching Off the Appliance When Not in Use

If you do not intend to use the appliance for an extensive period of time, set the thermostat knob to the **OFF** position and disconnect the power supply. Then take out the foods and clean the appliance. Leave the door slightly open.

### Disposing of a Worn Out Appliance

When your appliance finally wears out, dispose of it. If the appliance has a lock, break it to prevent possible accidents (danger of children getting locked inside the appliance).

### Energy-Saving Tips

- Try not to open the door too often, especially when the weather is hot and humid. Once you open the door, close it as soon as possible.
- Every now and then check if the appliance is sufficiently ventilated (adequate air circulation behind the appliance).
- Set thermostat from higher to lower settings as soon as possible (depending on how loaded the appliance is, the ambient temperature, etc.).
- The coils on the rear of the refrigerator should be cleaned and free of dust or any other impurities.

- An ice or frost layer increases energy consumption, so remove the frost as soon as the layer is 1/8" thick. See *Defrosting* on page 9.
- Be sure there is adequate clearance all around the unit, as described in *Installing Your Appliance* on page 4.

## Troubleshooting

While using your appliance, you may come across some problems that in most cases result from improper handling. Many of these can easily be eliminated by following the suggestions listed here.

*The appliance fails to operate after connecting to the power supply.*

- Check that there is power in the electrical socket.
- Make sure the appliance is switched on (thermostat is in the operating position).

*The refrigeration system is operating continuously.*

- The door was frequently opened or it was left open too long.
- The door is not properly closed (the door may sag; the gasket may be dirty or damaged).
- The appliance may be overloaded with fresh foods.
- There may be inadequate ventilation of the compressor and condenser. (Be sure there is sufficient air circulation. Wipe off the condenser.)

*Ice is forming on the inner rear wall.*

As long as the defrost water runs to the channel and through the opening to the drain pan on the compressor, automatic defrosting of the refrigerator compartment is assured. If the ice formation on the inner back wall increases to 1/8" or more, the ice should be manually defrosted as follows:

Set the thermostat knob to **OFF** and leave the door open. Never use electric devices for defrosting and do not scrape the ice or frost layer with sharp objects. When defrosting is completed, turn the knob to the desired position and close the refrigerator door.

Increased ice formation may be caused by one of the following:

- The door does not seal well (clean the gasket if it is contaminated, or replace it if it is damaged).
- The door was frequently opened or it was left open for too long.
- Food was warm when placed in the refrigerator.
- The food or a container is touching the inner back wall.

*Water is leaking from the refrigerator.*

In case the discharge water outlet is clogged or the defrost water drips over the channel resulting in water leaking from the refrigerator, just clean the clogged opening with a plastic straw. Manually defrost the increased ice layer. See *Ice is forming on the inner rear wall* above.

## Noise

Cooling in refrigerating-freezing appliances is enabled by the refrigerating system including the compressor, which produces noise. How noisy the appliance is depends on where it is placed, how it is used and how old the appliance is.

- During the operation of the compressor, a liquid sound is heard and when the compressor is not operating, a refrigerant flow is heard. This is a normal condition and it has no influence whatsoever on the lifetime of the appliance.
- After starting the appliance, the operation of the compressor and the refrigerant flow may be louder and this does not mean something is wrong with the appliance. The noise will reduce gradually. This will not affect the lifetime of the appliance.
- Sometimes strong noises occur which are unusual for the appliance. This noise is often a consequence of inappropriate placement. To avoid the noise make sure the appliance is placed and leveled firmly on a solid base. Make sure the appliance is not touching the wall or kitchen units standing next to it. And always make sure you check the accessories in the interior of the appliance; they should be placed correctly in their positions. Check the bottles, cans and other vessels that might touch each other and rattle.

## Before Calling for Service

- ✓ Check the plug and fuse.
- ✓ Test the outlet with a lamp.
- ✓ Be sure the temperature control dial is not set to **OFF**.
- ✓ Read the manual, especially the items under the *Installation, Operation and Care and Maintenance* sections. You may find the answers to your questions.
- ✓ If you don't find the answers to your questions in this manual, find the unit model number (on the upper back of the refrigerator) and contact Summit Customer Service at **(800) 932-4267**.

**Notes**

## Limited Warranty

### ONE-YEAR LIMITED WARRANTY

Within the 48 contiguous United States, for one year from the date of purchase, when this appliance is operated and maintained according to instructions attached to or furnished with the product, warrantor will pay for factory-specified parts and repair labor to correct defects in materials or workmanship. Service must be provided by a designated service company. Outside the 48 states, all parts are warranted for one year from manufacturing defects. Plastic parts, shelves and cabinets are warranted to be manufactured to commercially acceptable standards, and are not covered from damage during handling or breakage.

### 5-YEAR COMPRESSOR WARRANTY

The compressor is covered for 5 years.  
Replacement does not include labor.

#### **ITEMS WARRANTOR WILL NOT PAY FOR:**

- Service calls to correct the installation of your appliance, to instruct you how to use your appliance, to replace or repair fuses or to correct wiring or plumbing.
- Service calls to repair or replace appliance light bulbs or broken glass shelves. Consumable parts (such as filters) are excluded from warranty coverage.
- Damage resulting from accident, alteration, misuse, abuse, fire, flood, acts of God, improper installation, installation not in accordance with electrical or plumbing codes, or use of products not approved by warrantor.
- Replacement parts or repair labor costs for units operated outside the United States.
- Repairs to parts or systems resulting from unauthorized modifications made to the appliance.
- Expenses for travel and transportation for product service in remote locations.
- The removal and reinstallation of your appliance if it is installed in an inaccessible location or is not installed in accordance with published installation instructions.

### DISCLAIMER OF IMPLIED WARRANTIES; LIMITATION OF REMEDIES

CUSTOMER'S SOLE AND EXCLUSIVE REMEDY UNDER THIS LIMITED WARRANTY SHALL BE PRODUCT REPAIR AS PROVIDED HEREIN. IMPLIED WARRANTIES, INCLUDING WARRANTIES OF MERCHANTABILITY OR FITNESS FOR A PARTICULAR PURPOSE, ARE LIMITED TO ONE YEAR. WARRANTOR SHALL NOT BE LIABLE FOR INCIDENTAL OR CONSEQUENTIAL DAMAGES. SOME STATES DO NOT ALLOW THE EXCLUSION OR LIMITATION OF INCIDENTAL OR CONSEQUENTIAL DAMAGES, OR LIMITATIONS ON THE DURATION OF IMPLIED WARRANTIES OF MERCHANTABILITY OR FITNESS, SO THESE EXCLUSIONS OR LIMITATIONS MAY NOT APPLY TO YOU. THIS WARRANTY GIVES YOU SPECIFIC LEGAL RIGHTS AND YOU MAY ALSO HAVE OTHER RIGHTS, WHICH VARY FROM STATE TO STATE.

**WARNING!** This product may contain chemicals known to the state of California to cause cancer or birth defects or other reproductive harm. For more information, visit: [www.summitappliance.com/prop65](http://www.summitappliance.com/prop65)  
Chemicals known by the manufacturer to be present in this product in concentrations higher than threshold limits: NONE.

**Felix Storch, Inc.**  
Summit Appliance Division  
770 Garrison Avenue  
Bronx, NY 10474  
Phone: (718) 893-3900  
Fax: (844) 478-8799  
[www.summitappliance.com](http://www.summitappliance.com)

**SUMMIT**

For parts and accessory ordering,  
troubleshooting and helpful hints, visit:  
[www.summitappliance.com/support](http://www.summitappliance.com/support)