



Outdoor Kegerator Model SBC695OS

INSTRUCTION MANUAL

To ensure safe operation, please read this instruction manual thoroughly before use.

 **WARNING:** This product can expose you to chemicals including Nickel (Metallic) which is known to the State of California to cause cancer.
For more information go to www.P65Warnings.ca.gov
Note: Nickel is a component in all stainless steel and some other metal components.

FELIX STORCH, INC.
770 Garrison Avenue
Bronx, NY 10474
Phone: (718) 893-3900
Fax: (844) 478-8799
www.summitappliance.com

For parts and accessory ordering,
troubleshooting and helpful hints, visit:
www.summitappliance.com/support

Write Serial No. here:

FELIX STORCH, INC.
Summit Appliance Division
ISO 9001:2015 registered
770 Garrison Avenue
Bronx, New York 10474
www.summitappliance.com

Table of Contents

Important Safeguards	3-4
Installation Instructions	4
Guardrail Installation	4
Operation Instructions	5
Caster Installation	5
Installing The Handle	5
Reversing The Swing Of Your Appliance	6-9
Operating Your Appliance	10
Care and Maintenance	11
Energy Saving Tips	11
Troubleshooting	12
Limited Warranty	13

IMPORTANT SAFEGUARDS

Before using this appliance, it must be properly positioned and installed as described in this manual, so please read the manual carefully. To reduce the risk of fire, electrical shock or injury when using the appliance, follow these basic precautions. Failure to heed these safety requirements may result in severe personal injury or death.

DANGER

- Plug into a grounded 3-prong outlet. Do not under any circumstances cut or remove the third ground prong from the power cord supplied, do not use an adapter, and do not use an extension cord.
- It is recommended that a separate circuit, serving only your appliance be used. Do not use outlets that can be turned off by a switch or pull chain.
- Never clean appliance parts with flammable fluids and do not store or use gasoline or other flammable vapors and liquids in the vicinity of this or any other appliance. The fumes can create a fire hazard or explosion.
- Unplug the appliance or disconnect power before cleaning or servicing. Failure to do so can result in electrical shock or death.
- Do not attempt to repair or replace any part of your appliance unless it is specifically recommended in this manual. All other servicing should be referred to a qualified technician.
- This appliance is CFC- and HFC-free and contains small quantities of Isobutane (R600a) which is environmentally friendly, but flammable. It does not damage the ozone layer, nor does it increase the greenhouse effect. Care must be taken during transportation and setting up of the appliance that no parts of the cooling system are damaged. Leaking coolant can ignite and may damage the eyes.
In the event of any damage:
 - Avoid open flames and anything that creates a spark,
 - Disconnect from the electrical power line,
 - Air the room in which the appliance is located for several minutes, and
 - Contact the Service Department for advice.
- The more coolant there is in an appliance, the larger the room it should be installed in. In the event of a leakage, if the appliance is in a small room, there is the danger of combustible gases building up. For every ounce of coolant at least 325 cubic feet of room space is required. The amount of coolant in the appliance is stated on the data plate on the back of the appliance. It is hazardous for anyone other than an Authorized Service Person to carry out servicing or repairs to this appliance.
- Take serious care when handling, moving, and using the appliance to avoid either damaging the refrigerant tubing or increasing the risk of a leak.
- Replacing component parts and servicing shall be done by factory authorized service personnel so as to minimize the risk of possible ignition due to incorrect parts or improper service.

WARNING

- Use two or more people to move and install appliance. Failure to do so can result in back or other injury.
- To ensure proper ventilation for your appliance, the front of the unit must be completely unobstructed. Choose a well-ventilated area with temperatures above 50°F (10°C) and below 109.4°F (43°C). Do not install in a location where the unit will be exposed to direct sun exposure as this may result in unsatisfactory performance.
- The appliance should not be located next to ovens, grills or other high heat sources or in areas of extreme cold.
- The appliance must be installed in accordance with state and local codes. A standard electrical supply (110 V AC only, 60 Hz), properly grounded in accordance with the National Electrical Code and local ordinances is required.
- Do not kink or pinch the power supply cord of appliance.
- It is important for the appliance to be leveled in order to work properly.
- **DANGER! Risk of child entrapment!**
- Never allow children to operate, play with or crawl inside the appliance. Child entrapment and suffocation are not just problems of the past, junked or abandoned appliances are still dangerous. When no longer using your old appliance, take off the door and leave the shelves in place so that children may not climb inside easily.

- Do not use solvent-based cleansers or abrasives on the interior as they may damage or discolor the interior.
- Because of potential safety hazards under certain conditions, it is strongly recommended that you do not use an extension cord with this appliance. However, if you must use an extension cord, it is absolutely necessary that it be a UL/CUL-Listed, 3-wire grounding type appliance extension cord having a grounding type plug and outlet and that the electrical rating of the cord be 110 volts.
- If the appliance is going to be used in an area that is prone to power surges/outages, it is suggested that you use a power surge protector. The surge protector that you select must have a surge block high enough to protect the appliance it is connected to. Damages due to power surges are not considered a manufacturer covered defect and will void your product warranty.
- The cord should be secured behind the appliance and not left exposed or dangling to prevent accidental injury. Never unplug the appliance by pulling the power cord. Always grip the plug firmly and pull straight out from the receptacle. Repair or replace immediately all power cords that have become frayed or otherwise damaged. Do not use a cord with cracks or abrasion damage along its length or at either end. When moving the appliance, be careful not to damage the power cord.
- Do not use this apparatus for other than its intended purpose.

SAVE THESE INSTRUCTIONS.

Installation Instructions

BEFORE USE:

- Remove the exterior and interior packaging, but do not remove any foam insulation surrounding the pipes at the back.
- Before connecting the unit to the power source, let it stand upright for approximately 24 hours. This will reduce the possibility of a malfunction in the cooling system from handling during transportation.
- Clean the interior surface with lukewarm water using a soft cloth.
- Place the unit on a flat, solid floor that is strong enough to support it when it is fully loaded. To level the appliance, adjust the rolling casters at the bottom of the unit.
- When moving your refrigerator, please do not incline it more than 45 degrees.
- Locate the appliance away from direct sunlight and sources of heat (stove, heater, radiator, etc.). Direct sunlight may affect the acrylic coating and heat sources may increase electrical consumption. Extreme cold ambient temperatures may also cause the unit to perform improperly. The optimal ambient temperature range is 50°F – 109.4°F. Do not mount the draft tower remotely, as the exposed beer line will not be refrigerated, causing foam.
- Avoid locating the unit in damp areas.
- Unwind the power cord to its full length and inspect for damage before plugging into the outlet.
- Plug the refrigerator into an exclusive, properly installed and grounded wall outlet. Do not under any circumstances cut or remove the third (ground) prong from the power cord. Any questions concerning power and/or electrical grounding should be directed to a certified electrician or authorized products service center.
- After plugging the appliance into a wall outlet, allow the unit to cool down for 3 to 4 hours before installing a keg in the appliance.

Guardrail Installation

1. Place the guardrail on top of the beer dispenser and line up the feet with the holes on top of the cabinet
2. Using the screws provided, secure each foot to the cabinet

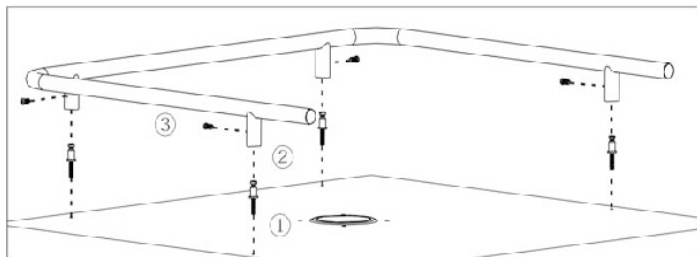

LIMITED WARRANTY

One-year Limited Warranty

Within the 48 contiguous United States, for one year from the date of purchase, when this appliance is operated and maintained according to instructions attached to or furnished with the product, warrantor will pay for factory-specified parts and repair labor to correct defects in materials or workmanship. Service must be provided by a designated service company. Outside the 48 states, all parts are warranted for one year from manufacturing defects. Plastic parts, shelves and cabinets are warranted to be manufactured to commercially acceptable standards, and are not covered from damage during handling or breakage.

5-years Compressor Warranty

1. The compressor is covered for 5 years.
2. Replacement does not include labor.

ITEMS WARRANTOR WILL NOT PAY FOR:

1. Service calls to correct the installation of your appliance, to instruct you how to use your appliance, to replace or repair fuses or to correct wiring or plumbing.
2. Service calls to repair or replace appliance light bulbs or broken shelves. Consumable parts (such as filters) are excluded from warranty coverage.
3. Damage resulting from accident, alteration, misuse, abuse, fire, flood, acts of God, improper installation, installation not in accordance with electrical or plumbing codes, or use of products not approved by warrantor.
4. Replacement parts or repair labor costs for units operated outside the United States.
5. Repairs to parts or systems resulting from unauthorized modifications made to the appliance.
6. The removal and reinstallation of your appliance if it is installed in an inaccessible location or is not installed in accordance with published installation instructions.

Disclaimer Of Implied Warranties – Limitation Of Remedies

CUSTOMER'S SOLE AND EXCLUSIVE REMEDY UNDER THIS LIMITED WARRANTY SHALL BE PRODUCT REPAIR AS PROVIDED HEREIN. IMPLIED WARRANTIES, INCLUDING WARRANTIES OF MERCHANTABILITY OR FITNESS FOR A PARTICULAR PURPOSE, ARE LIMITED TO ONE YEAR. WARRANTOR SHALL NOT BE LIABLE FOR INCIDENTAL OR CONSEQUENTIAL DAMAGES. SOME STATES DO NOT ALLOW THE EXCLUSION OR LIMITATION OF INCIDENTAL OR CONSEQUENTIAL DAMAGES, OR LIMITATIONS ON THE DURATION OF IMPLIED WARRANTIES OF MERCHANTABILITY OR FITNESS, SO THESE EXCLUSIONS OR LIMITATIONS MAY NOT APPLY TO YOU. THIS WARRANTY GIVES YOU SPECIFIC LEGAL RIGHTS AND YOU MAY ALSO HAVE OTHER RIGHTS, WHICH VARY FROM STATE TO STATE.

Troubleshooting

There are many common issues you may experience with your kegerator that can be solved very easily, without the need of a service call. Try the tips below to troubleshoot your unit should you experience any problems:

PROBLEM	POSSIBLE CAUSE
Kegerator does not operate	Not plugged in or the appliance is turned off The circuit breaker tripped or a fuse has blown out
Kegerator is not cold enough	Check the temperature control setting External environment may require a higher setting The door is opened too often The door is not closed completely The door gasket is not sealing properly
Kegerator is turning on and off frequently	The room temperature is hotter than normal. The door is opened too often. The door is not closed completely. The temperature control is not set correctly. The door gasket does not seal properly.
The light does not work	Not plugged in. The circuit breaker tripped or a fuse has blown. The light bulb has burned out. The light button is "OFF".
Vibrations	Check to assure that the kegerator is on a level surface.
The kegerator seems to make too much noise	A faint humming noise may come from the flow of the refrigerant, which is normal. As each cycle ends, you may hear gurgling sounds caused by the flow of refrigerant in your kegerator. Contraction and expansion of the inside walls may cause popping and crackling noises. During the defrosting process you may hear a water flowing sound caused by water flowing into the drain trough. The kegerator is not on a level surface.
The door will not close properly	The kegerator is not on a level surface. The gasket is dirty. The shelves are out of position.
Smell/odor	Check for spills and for food or drink that is out of date or incorrectly packaged
Outer surface of appliance is wet	Condensation has formed and can be wiped dry
External surface is warm	Compressor is working to transfer heat from inside the cabinet

Operation Instructions

The Kegerator is able to maintain the proper dispensing temperature for beer, provided it is installed correctly in the proper environment. For best results, mount the draft tower as close to the top of the kegerator as possible and seal any openings to prevent heat transfer. Avoid opening and closing the door of the kegerator too often to ensure a consistent temperature inside the unit. Factory preset temperature is 34 degrees Fahrenheit.

The kegerator should be placed in an area where the ambient temperature range is between 50-109.4 degrees Fahrenheit (10-43 degrees Celsius). If the ambient temperature is above or below this range, the performance of the unit may be affected. For example, placing your unit in extreme cold or hot conditions may cause interior temperatures to fluctuate. Please be aware that the desired temperatures may fluctuate depending on the ambient temperature and the orientation of the keg.

Caster Installation

1. Remove everything from the cabinet and lay the unit on a clean, dry, and padded surface
2. Install casters into the holes on the bottom of the unit as shown and tighten with a wrench

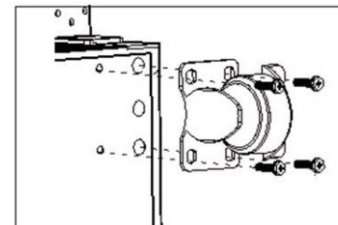

3. The two casters equipped with locks should be installed on the front of the unit
4. Once all four casters are attached, return the beer dispenser to an upright position
5. Allow the unit to sit for 8-10 hours before plugging in to allow the refrigerant to settle

INSTALLING THE HANDLE

This appliance includes a stainless-steel handle that is not required to operate this unit. To install the handle please follow the below instructions:

1. Pull away the door gasket in the area where the handle is to be installed as shown in Illustration. The gasket is easily displaced by hand, no tools are necessary.
2. Locate the screws included in the bag with the user's guide. Insert the screws into the holes as shown.
3. Align the handle with the screws installed. Tighten the screws using a Phillips head screwdriver until the handle sets both flush and secured tightly against the door frame. (DO NOT over tighten as this will cause damage to the handle assembly).
4. Replace the door gasket to its original position.

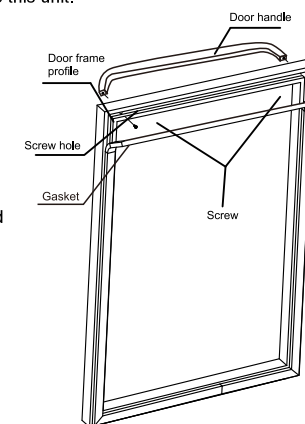

REVERSING THE DOOR SWING OF YOUR APPLIANCE

This unit has the capability of the door opening from either the left or right side. The unit is delivered to you with the door opening from the left side. Should you desire to reverse the opening direction, please follow the reversal instructions shown below.

NOTE: All parts removed must be saved to allow the door swing to be reversed.



Before reversing the door swing, please read and follow the reversal instructions below carefully. Skipping steps might result in unexpected personal injury. To Prevent Serious Injury, Wear Eye and Hand Protection.

Door parts

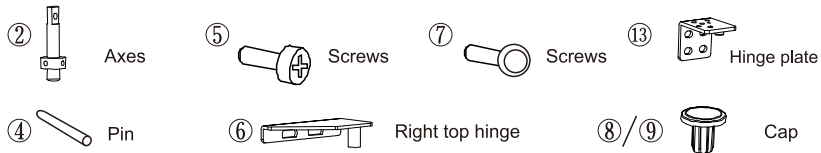

Included parts



- 1**
- A** Take out two hex keys from a bag in cabinet. Insert the small hex key ① to the axes ②.
 - B** Rotating the axes ② by clockwise.
 - C** Use the big hex key ③ to push the pin ④ until you can take out the pin by hand.

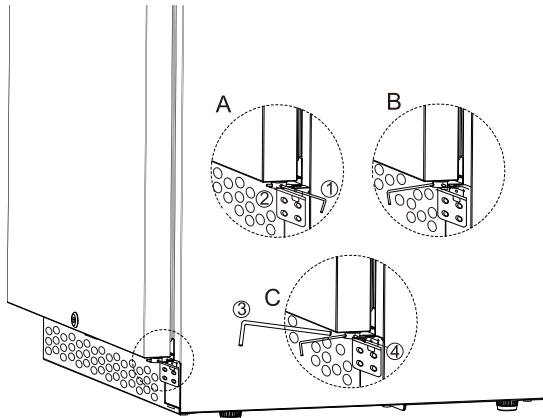

Care and Maintenance

Cleaning your kegerator:

- Turn off the power, unplug the appliance, and remove all items including the dispense kit.
- Wash the inside surfaces with warm water and baking soda solution. The solution should be about 2 tablespoons of baking soda to a quart of water.
- Wring excess water out of the sponge or cloth when cleaning area of the controls, or any electrical parts.
- Wash the outside cabinet with warm water and mild liquid detergent. Rinse and wipe dry with a clean soft cloth.
- Do not use steel wool or a steel brush on the stainless steel. These will contaminate the stainless steel with steel particles and rusting may occur.
- Dust the front grill and back of the unit twice yearly. Make sure the power is off before cleaning.
- It is recommended to clean the unit completely inside and out yearly to maximize the longevity of the product.

Moving your kegerator:

- The provided casters will allow you to roll the appliance from one location to another in your home easily.
- For transportation, remove the keg, the dispense kit and any other items you may have inside the unit.
- Securely tape down all loose items inside your appliance and tape the door shut.
- Be sure the appliance stays secure in the upright position during transportation.
- Protect the outside of the appliance with a blanket or similar item.

Energy Saving Tips

- Place the unit in the coolest area of the room, away from heat-producing appliances and out of direct sunlight
- Let heated items and beverages cool to room temperature before placing them into the appliance
- Do not overload the beer dispenser as it forces the compressor to run longer
- Wrap items properly and wipe containers dry before placing them in the unit to cut down on frost build-up
- Do not line shelves with aluminum foil, wax paper, or paper towels, as liners can interfere with cold air circulation, reducing cooling efficiency
- Position items so that air can circulate freely around them
- Do not leave door open for longer than required
- Make sure items do not touch the back of the storage compartment
- Do not set the thermostat to exceedingly cold temperatures

OPERATING YOUR APPLIANCE

It is recommended that you install the appliance in a place where the ambient temperature is between 50°F and 109.4°F (10°C- 43°C). If the ambient temperature is above or below recommended temperatures, the performance of the unit may be affected. For example, placing your unit in extremely cold or hot conditions may cause interior temperatures to fluctuate. The operating temperature range may not be reached.

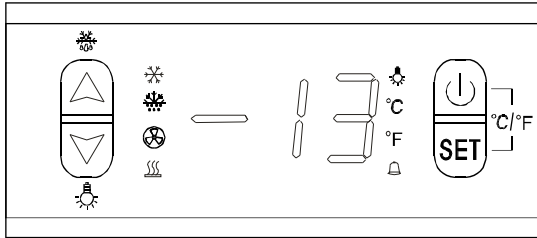

CONTROL PANEL



ON/OFF Power



To turn the appliance ON or OFF, press and hold the POWER key  for 5 seconds.

UP and DOWN



Press  first, then press  or  button to increase (warm) or decrease (cool) the set temperature by 1°C/1°F.

Press  again, the temperature is selected and shows the actual temperature. If no other further operation in 6 seconds, display will show actual temperature in the cooler.

°C/°F Selector

Selects the temperature display setting in Fahrenheit or Celsius degrees. To change the temperature from Fahrenheit to Celsius or from Celsius to Fahrenheit, press  and  at the same time, then hold for 6 seconds.

Setting the Temperature Control



The temperature you are setting will increase by one degree each time you press the  key, and will decrease by one degree each time you press the  key.

The range of the temperature control is from 32°F to 50°F.

To view the set temperature at any time, press the  key. The set temperature will flash in the display window for 6 seconds. After 6 seconds, the temperature inside the unit will reappear in the display window.



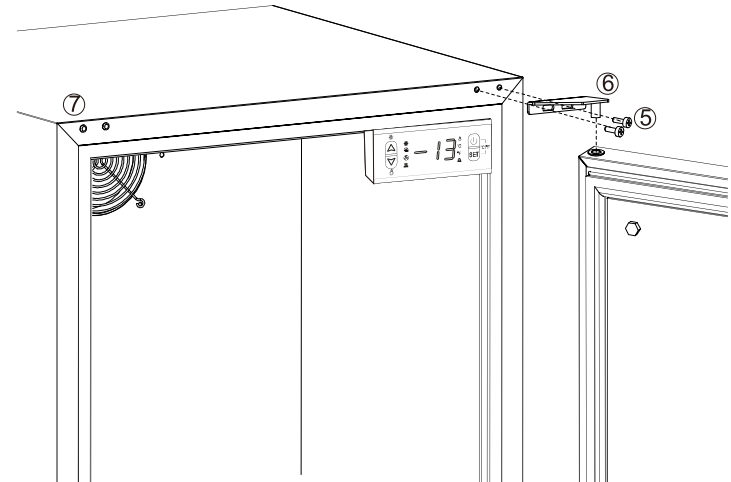

(The temperature preset at the factory is 34°F).

2

- Remove the top right screws  from right top hinge . Gently pull down the door and place it on a padded surface to avoid the risk of damage.
- Transfer the top left screws  to cover the top right holes.



3

- To hang the axes  to the opposite and put the caps  and  to cover the holes  and  at the same time.

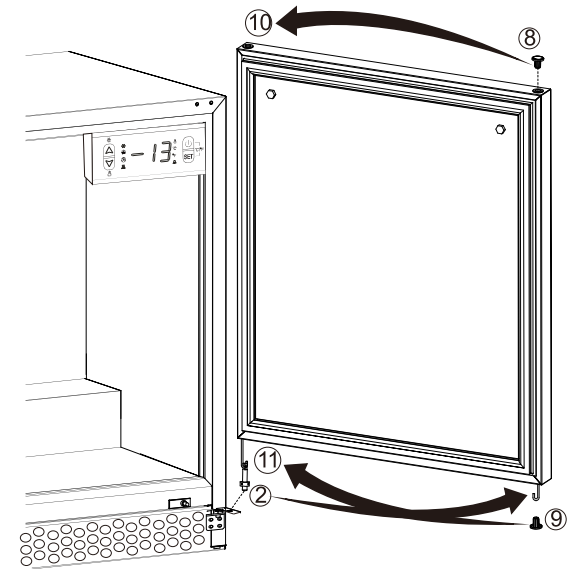

4

- Remove the screws ⑤ from hinge plate ⑬.
- Place the hinge plate ⑬ on the bottom left.
- Fix the screws ⑤ on the hinge plate ⑬.

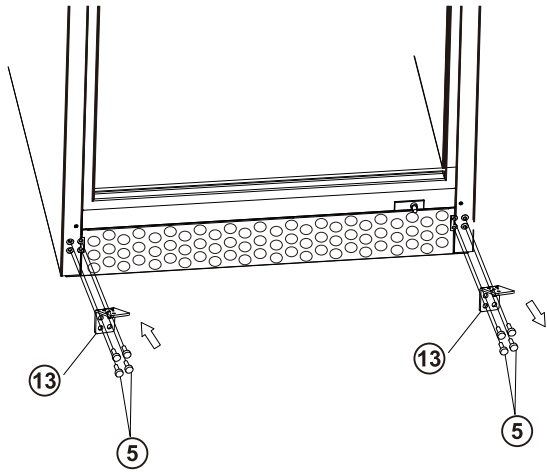
**6**

- Screw the alternative left top hinge ⑫, included in the fitting, onto the left hand side of cabinet and tighten it after the door is leveled.

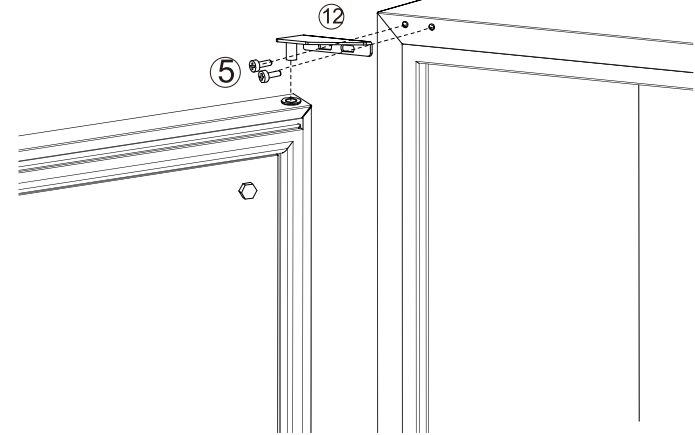
**5**

- Place the axes ② on the left hinge plate.

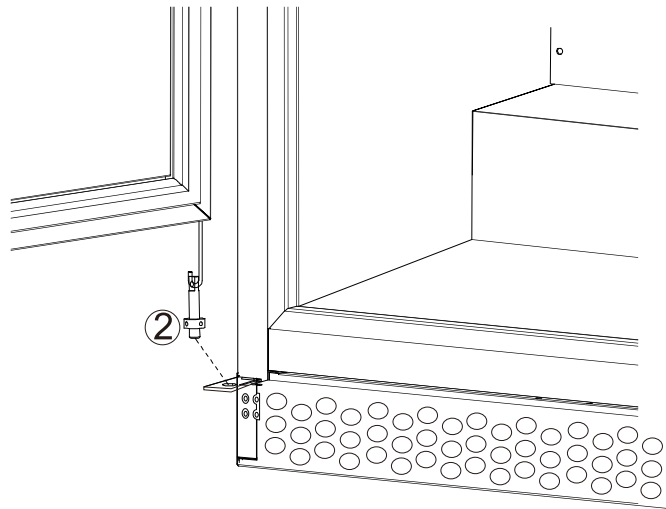
**7**

- A** Loosen the small screw a little higher (around 0.3inch), make sure the pin not higher than this screw.
- B** Use the small hex key ① to rotate the axes ② anticlockwise.
- C** Insert the pin ④ when you get the desired intensity for self-closing.

