

609.6(24")

246.1(9-11/16")

166.4(6-35/64")

G. FILLER BLOCK AREA

D. DRILL 3/8" DIAMETER

H. FILLER BLOCK AREA

E. DRILL 3/8" DIAMETER

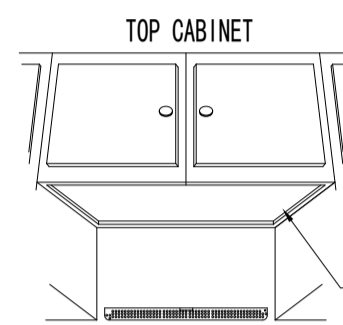

FIG. 1

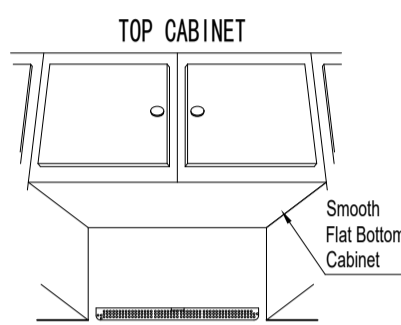

FIG. 2

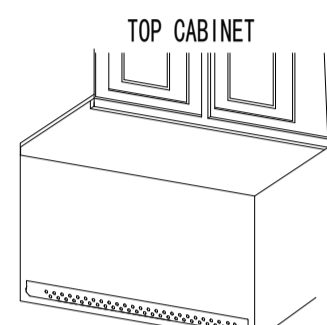

FIG. 3

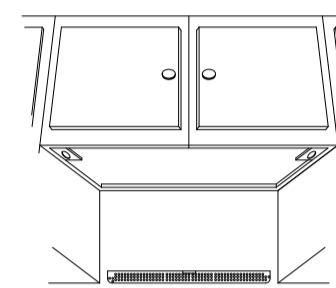

FIG. 4

NOTE: IT IS VERY IMPORTANT TO READ AND FOLLOW THE DIRECTIONS IN THE INSTALLATION INSTRUCTIONS BEFORE PROCEEDING WITH THIS TOP CABINET TEMPLATE.

This template is used to locate the power cord clearance hole, cabinet mounting holes, and the vertical exhaust cutout.

1. Determine if your cabinet has a recessed area or a smooth, flat bottom. See Fig. 1. If smooth, tape template onto the bottom surface (Fig. 2). If it is recessed, cut the edges of the template to fit in the recessed bottom of the cabinet. It is important that the edges of the cabinets permit level installation of the oven.

NOTE: On some cabinets a small bracket or glue block is used between the overhang and the underside of the cabinet bottom. Cut the template to fit around the bracket or glue block so that template will lie flat against the bottom of the cabinet. Tape the Top Cabinet Template to the underside of the top cabinet in the recessed area Fig. 3.

Note: Make sure the rear of the template touches the back wall (for smooth, flat bottom cabinets) or the back of the recess (for recessed bottom cabinets) after cutting the edges of the template.

TOP CABINET TEMPLATE

24" MINIMUM WIDTH REQUIRED

F. POWER CORD

DRILL 2" DIAMETER

CAUTION-IF EXHAUST ADAPTOR IS POSITIONED OUTSIDE RECOMMENDED DIMENSION, GREASE LADEN AIR WILL DISCHARGE INTO HOUSE STRUCTURE.

I. CUT OUT FOR VERTICAL (OUTSIDE) EXHAUST ONLY

CUT HOLE THROUGH CABINET BOTTOM FOR EXHAUST ADAPTOR

11 3/4"

5.5"

249.7(9-27/32")

280 (11 1/64")

GUIDELINES FOR THICKNESS C.

RIGHT SIDE

1" 3/4" 1/2" 1/4"

GUIDELINES FOR THICKNESS A.

249.7(9-27/32")

LEFT SIDE

1" 3/4" 1/2" 1/4"

GUIDELINES FOR THICKNESS B.

1/4" 1/2" 3/4" 1"

WALL

WALL

ADJUSTABLE 1/2" MIN. 1" MAX.