



REFRIGERATOR-FREEZER

Models:

FF101W	LF103W	FFRF105W
FF102PL	LF104PL	FFRF106PL

User Manual

BEFORE USE, PLEASE READ AND FOLLOW ALL SAFETY RULES AND OPERATING INSTRUCTIONS IN THIS MANUAL.

Write Serial No. (on back of unit) here:

Felix Storch, Inc.
Summit Appliance Division
An ISO 9001:2015 registered company
770 Garrison Avenue Bronx, New York 10474
www.summitappliance.com

TABLE OF CONTENTS

Appliance Safety	3
Important Safeguards	3-4
Location of Parts	5
Installation Instructions	6-10
<i>Before Using your Appliance</i>	6
<i>Installation of your Appliance</i>	6
<i>Leveling your Appliance</i>	6
<i>Electrical Connection</i>	7
<i>Extension Cord</i>	7
<i>Reversing the Door Swing</i>	8-10
Operating Instructions	10
Care and Maintenance	11-12
<i>Cleaning your Appliance</i>	11
<i>Cleaning the Glass Shelves</i>	11
<i>Defrosting</i>	11
<i>Power Failure</i>	11
<i>Moving</i>	12
<i>Vacations</i>	12
Troubleshooting	13
Limited Warranty	16

APPLIANCE SAFETY

Your safety and the safety of others are very important.

We have provided many important safety messages in this manual and on your appliance. Always read and obey all safety messages.



This is the Safety Alert Symbol. The symbol alerts you to potential hazards that can kill or injure you and others. All safety messages will follow the Safety Alert Symbol and either the word DANGER or WARNING.



DANGER means that failure to heed this safety statement may result in severe personal injury or death.



WARNING means that failure to heed this safety statement may result in extensive product damage, serious personal injury, or death.

All safety messages will alert you about the potential hazard, tell you how to reduce the chance of injury, and let you know what can happen if the instructions are not followed.

IMPORTANT SAFEGUARDS



Before the appliance is used, it must be properly positioned and installed as described in this manual, so read the manual carefully. To reduce the risk of fire, electrical shock or injury when using the appliance, follow basic precautions, including the following:



- Plug into a grounded 3-prong outlet, do not remove grounding prong, do not use an adapter, and do not use an extension cord.
- Replace all panels before operating.
- It is recommended that a separate circuit serving only your appliance be provided. Use receptacles that cannot be turned off by a switch or pull chain.
- Never clean appliance parts with flammable fluids. These fumes can create a fire hazard or explosion. And do not store or use gasoline or other flammable vapors and liquids in the vicinity of this or any other appliance. The fumes can create a fire hazard or explosion.
- Do not connect or disconnect the electric plug when your hands are wet.
- Unplug the appliance or disconnect power before cleaning or servicing. Failure to do so can result in electrical shock or death.
- Do not attempt to repair or replace any part of your appliance unless it is specifically recommended in this manual. All other servicing should be referred to a qualified technician.
- This appliance is CFC- and HFC-free and contains small quantities of Isobutane (R600a) which is environmentally friendly, but flammable. It does not damage the ozone layer, nor does it increase the greenhouse effect. Care must be taken during transportation and setting up of the appliance that no parts of the cooling system are damaged. Leaking coolant can ignite and may damage the eyes.

- In the event of any damage:
 - Avoid open flames and anything that creates a spark,
 - Disconnect from the power supply
 - Air the room in which the appliance is located for several minutes and
 - Contact the Service Department for advice.
- The more coolant there is in an appliance, the larger the room it should be installed in. In the event of a leakage, if the appliance is in a small room, there is the danger of combustible gases building up. For every ounce of coolant, at least 325 cubic feet of room space is required. The amount of coolant in the appliance is stated on the data plate inside the appliance. It is hazardous for anyone other than an Authorized Service Person to carry out servicing or repairs to this appliance.
- Take serious care when handling, moving and using the appliance to avoid either damaging the refrigerant tubing or increasing the risk of a leak.
- Replacing component parts and servicing shall be done by factory authorized service personnel, so as to minimize the risk of possible ignition due to incorrect parts or improper service.

WARNING

FOLLOW WARNING CALLOUTS BELOW ONLY WHEN APPLICABLE TO YOUR MODEL

- Use two or more people to move and install appliance. Failure to do so can result in back or other injury.
- To ensure proper ventilation for your appliance, the front of the unit must be completely unobstructed. Choose a well-ventilated area with temperatures above 44°F (7°C) and below 90°F (32°C).
- The appliance should not be located next to ovens, grills or other sources of high heat.
- The appliance must be installed with all electrical, water and drain connections in accordance with state and local codes. A standard electrical supply (115 V AC only, 60 Hz), properly grounded in accordance with the National Electrical Code and local codes and ordinances, is required.
- Do not kink or pinch the power supply cord of the appliance.
- The size of the fuse (or circuit breaker) should be 15 amperes.
- It is important that the appliance be leveled in order to work properly. You may need to make several adjustments to level it.
- All installations must be in accordance with local plumbing code requirements.
- Make certain that the pipes are not pinched, kinked or damaged during installation.
- Check for leaks after connection.
- Never allow children to operate, play with or crawl inside the appliance.
- Do not use solvent-based cleaning agents or abrasives on the interior. These cleaners may damage or discolor the interior.
- Use this appliance only for its intended purpose as described in this *Instruction Manual*.
- Keep fingers out of the “pinch point” areas. Clearances between the door and cabinet are necessarily small. Be careful closing the door when children are in the area.

DANGER

Risk of child entrapment!

Child entrapment and suffocation are not problems of the past. Junked or abandoned appliances are still dangerous, even if they will “just sit for a few days”.

Before discarding your old appliance:

- *Take off the doors*
- *Leave the shelves in place so that children may not easily climb inside.*

- SAVE THESE INSTRUCTIONS -

LOCATION OF PARTS

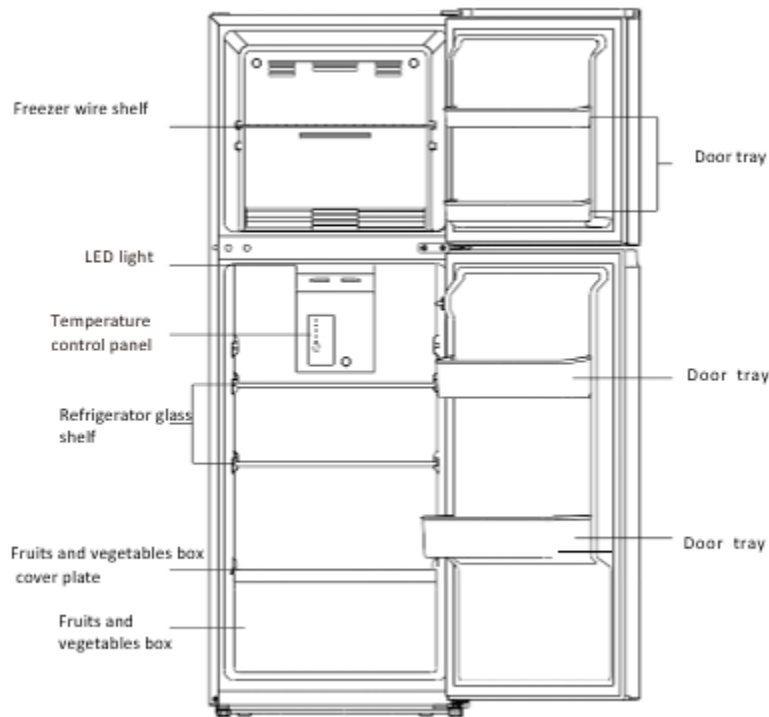

NOTE: The picture above is for reference only. The actual configuration of your unit may differ.

Refrigerated Chamber

- The refrigerated chamber is suitable for storage of a variety of fruits, vegetables, beverages and other food consumed in the short term.
- Let any cooked foods cool to room temperature before storage
- Seal any foods before storage
- The glass shelves can be adjusted up or down for a reasonable amount of storage space and easy use.

Freezer Chamber

- The low temperature freezing chamber may keep food fresh for a long time and is used to store frozen foods and making ice.
- The freezing chamber is suitable for storage of meat, fish, vegetables, and other foods not to be consumed in short term.
- Large portions of meat are should be divided into smaller pieces for easy access. Consume all foods within the proper shelf time.

INSTALLATION INSTRUCTIONS

Before Using your Appliance

- Remove the exterior and interior packing.
- Before connecting the appliance to the power source, let it stand upright for approximately 2 hours. This will reduce the possibility of a malfunction in the cooling system from handling during transportation.
- Clean the interior surface with lukewarm water using a soft cloth.
- Install the handle on the door, if it is not already attached.

Installation of your Appliance

- The appliance is designed free standing installation for indoor use.

CAUTION: *This appliance is not designed for the storage of medicine or other medical products.*

- Place your appliance on a floor that is strong enough to support it when it is fully loaded. To level the unit, adjust the front leveling legs.
- Keep 4" of space between the back and the sides of the unit and 11" at the top to allow proper air circulation to cool the compressor and condenser.
- Keep away from heat and avoid direct sunlight. Do not place the unit in moist or watery places to prevent rust or reduction of insulating effect.
- Plug the appliance into an exclusive, properly grounded wall outlet.

Leveling your Appliance

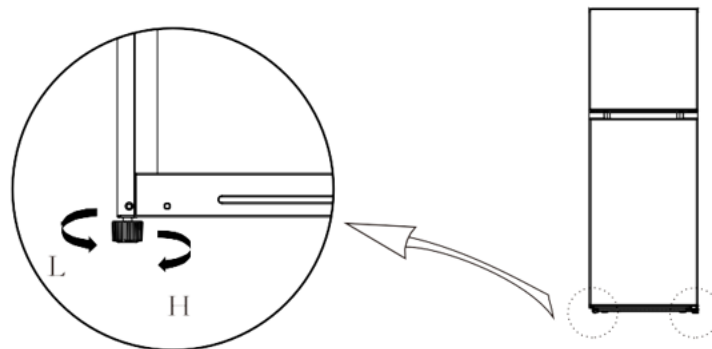

Adjust the left and right front leveling feet to ensure your refrigerator-freezer is on a horizontal level.

- Turn the front leveling feet clockwise to increase the height of your refrigerator-freezer.
- Turn the front leveling feet counterclockwise to lower the height of your refrigerator-freezer

Electrical Connection



WARNING

Improper use of the grounded plug can result in the risk of electrical shock. If the power cord is damaged, have it replaced by a qualified electrician or an authorized service center.

This appliance should be properly grounded for your safety. The power cord of this appliance is equipped with a three-prong plug which mates with standard three-prong wall outlets to minimize the possibility of electrical shock.

Do not under any circumstances cut or remove the third (ground) prong from the power cord supplied. For personal safety, this appliance must be properly grounded. Any questions concerning power and/or grounding should be directed toward a certified electrician or an authorized service center.

This appliance requires a standard 115/120 Volt AC ~60Hz three-prong grounded electrical outlet. Have the wall outlet and circuit checked by a qualified electrician to make sure the outlet is properly grounded. When a standard 2-prong wall outlet is encountered, it is your responsibility and obligation to have it replaced with a properly grounded 3-prong wall outlet.

To prevent accidental injury, the cord should be secured behind the appliance and not left exposed or dangling.

The appliance should always be plugged into its own individual electrical outlet which has a voltage rating that matches the rating label on the appliance. This provides the best performance and also prevents overloading house wiring circuits that could cause a fire hazard from overheating. Never unplug the appliance by pulling on the power cord. Always grip the plug firmly and pull straight out from the receptacle. Repair or replace immediately all power cords that have become frayed or otherwise damaged. Do not use a cord that shows cracks or abrasion damage along its length or at either end. When moving the appliance, be careful not to damage the power cord.

Extension Cord

Because of potential safety hazards under certain conditions, it is strongly recommended that you do not use an extension cord with this appliance. However, if you must use an extension cord, it is absolutely necessary that it be a UL/CUL-Listed, 3-wire grounding type appliance extension cord having a grounding type plug and outlet and that the electrical rating of the cord be 115 volts and at least 10 amperes.

Reversing the Door Swing

If you find the direction of opening the door of the appliance inconvenient, you can change it. Holes on the opposite side have already been prepared at the factory. To reverse your door, follow the instruction on the next page.

Tools needed:

- Phillips head screwdriver
- Flat-head screwdriver
- Putty knife
- 5/16" socket and ratchet
- Masking tape

1. Unplug the appliance, and remove all items from the door shelves and the interior.
2. Remove the hinge hole cover from the top left side of the appliance.
3. Remove the upper hinge cover from the top right side of the appliance. Then, remove the hinge screws and upper hinge.
4. Lift the upper door off of the cabinet.

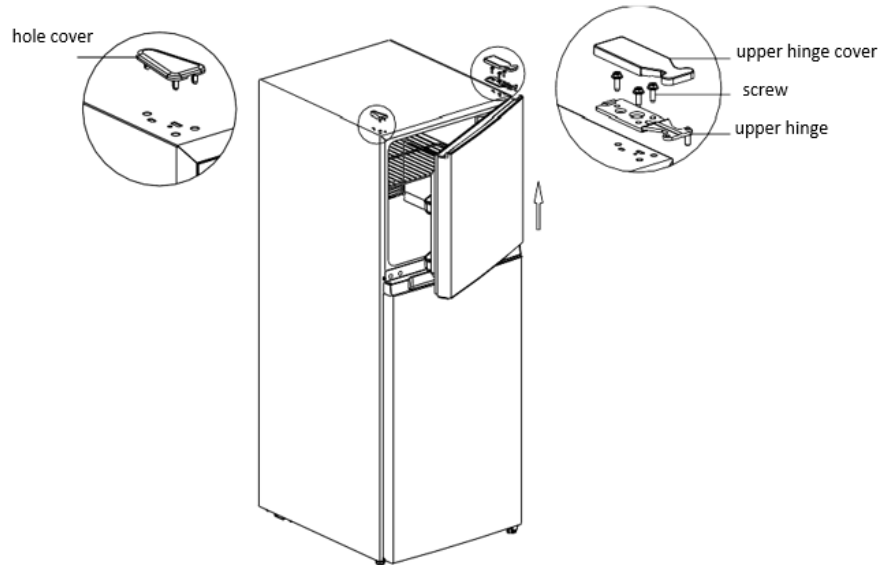

5. Place the upper door on a soft surface to ensure the door is not scratched or damaged.
6. Unscrew the middle hinge screws, and remove the middle hinge.
7. Remove the two hinge hold plugs, the screw, and screw cap from the middle beam on the opposite side of the appliance.
8. Remove the refrigerator door from the cabinet.

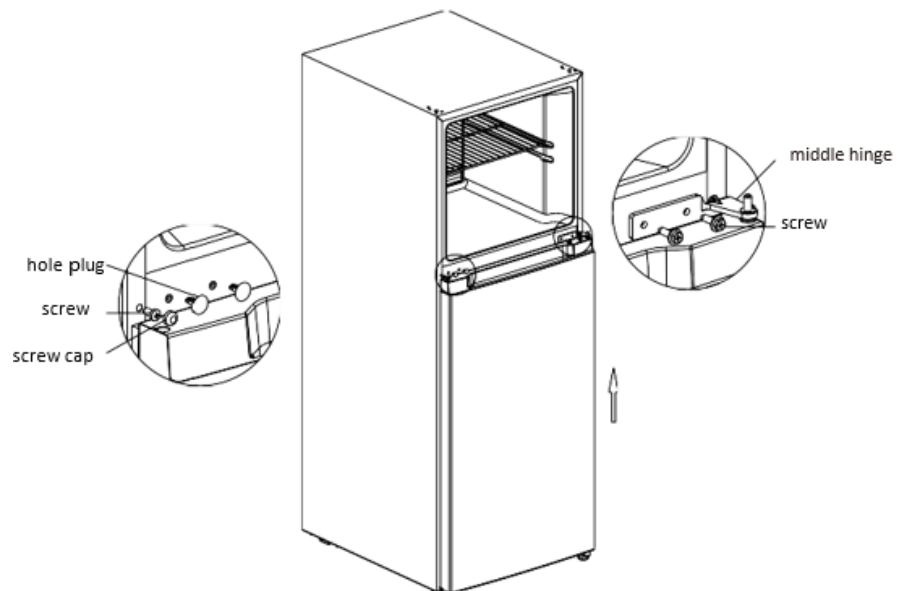

9. Carefully tip the unit back, and remove the adjusting feet, lower hinge screws, and the lower hinge assembly.
10. Install the lower hinge assembly on the other side of the cabinet, and install the adjusting feet again.

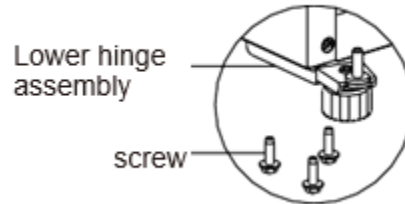

11. Dismantle the limit blocks and screws on the lower cover of the refrigerator and freezer door. Install them on the opposite side of both doors. Then, install the sleeve pipe on the upper cover of the refrigerator door on the other side.

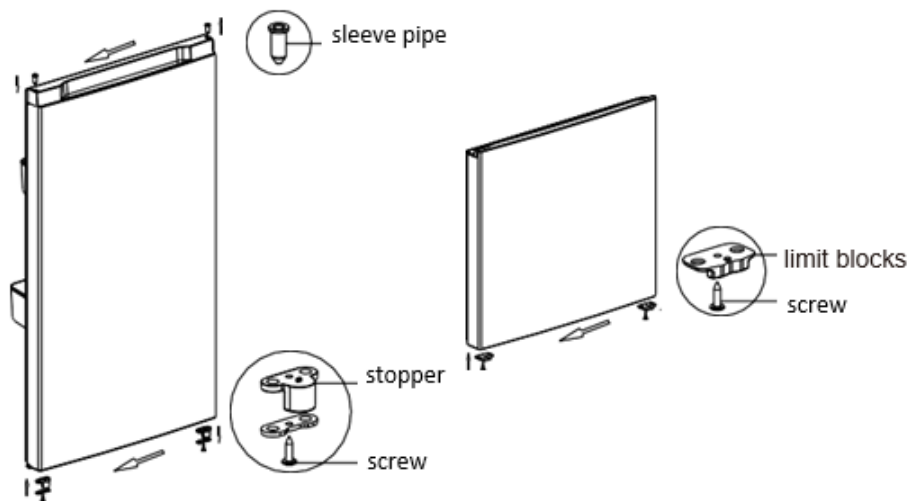

12. Set the refrigerator door onto the lower hinge, and then install the middle hinge and hinge hole caps.

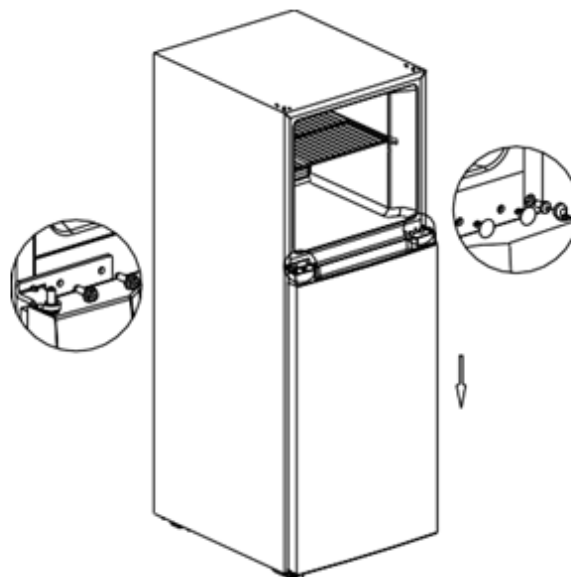

- Set the freezer door onto the middle hinge, and then install the upper hinge to secure the freezer door, making sure to secure the hinge cover and hinge hole cover.

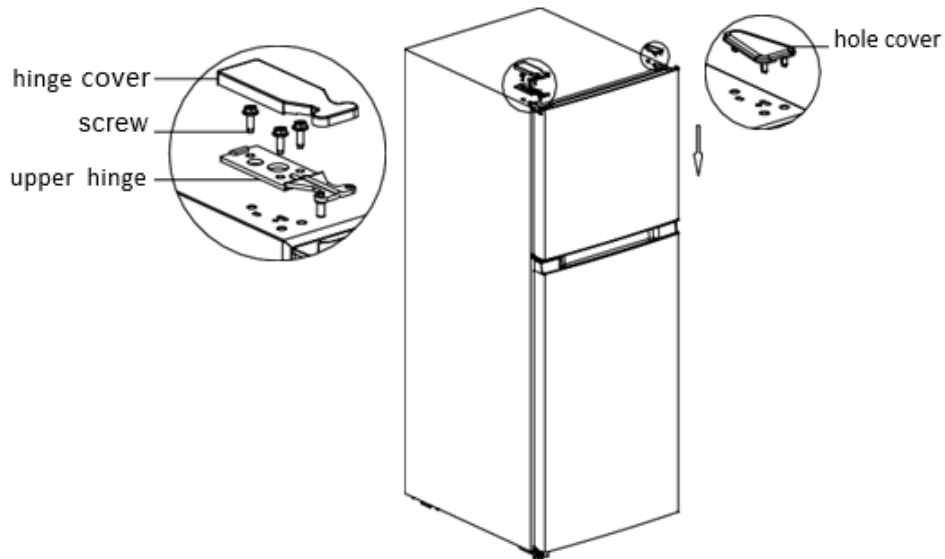



Changing the Interior Light

Replacing the LED lamps should be done by the manufacturer or qualified technician.

OPERATING YOUR APPLIANCE

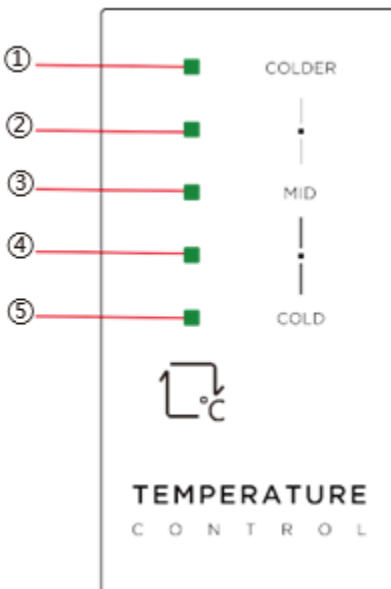
Control Panel



- The control panel features a SET  key and five temperature settings.
- The settings cycle from 1 (coldest) to 5 (least cold) each time the SET key is pressed.

Error Codes

When an error occurs, the corresponding LED light combination corresponds to the specific error:

Error Code	Error Description
LED 1 and 2 flashing	Temperature sensor failure in refrigerator
LED 1 and 3 flashing	Temperature sensor failure in the freezer
LED 1 and 4 flashing	Ring temperature sensor failure

CARE AND MAINTENANCE

CAUTION: Be sure to unplug the appliance before cleaning to avoid the risk of electric shock.

Cleaning your Appliance

- Dust accumulates behind and on the unit should be cleaned regularly to ensure cooling efficiency and energy consumption.
- Check the door gasket regularly to make sure there is no accumulated debris. Clean the door gasket with a soft cloth dampened with soapy water or diluted detergent.
- The interior of the refrigerator should be cleaned regularly to avoid any odor buildup.
- Do not use soap, detergent, scrub powder, spray cleaner, etc., as these may cause odors in the interior of the refrigerator.
- Use a soft cloth or sponge to clean the inside of the unit, using a solution of two tablespoons of baking soda and a quart of warm water. Then rinse with clean water, and then wipe clean with a soft towel. After cleaning, open the door and let the unit dry naturally before turning the power back on.
- For areas that are difficult to clean in (such as narrow gaps or corners), it is recommended to wipe them regularly with a soft rag or brush, or when necessary, an auxiliary tool (such as a thin stick) to ensure no contaminant or bacterial accumulation in these areas.
- Clean the bottle frame, shelves and drawers with a soft cloth dampened with soapy water or diluted detergent. Dry with a soft cloth.
- Wipe the outer surface of the unit with a soft cloth dampened with soapy water or diluted detergent, and then wipe dry.
- Do not use hard brushes, clean steel balls, wire brushes, abrasives (such as toothpastes), organic solvents (such as alcohol, acetone, banana oil, etc.), boiling water, acid or alkaline items, which may damage the surface and interior of the unit. Boiling water and organic solvents such as benzene may deform or damage plastic parts.
- Do not rinse directly with water or other liquids during cleaning to avoid short circuits or potentially affect the electrical insulation.

Cleaning the Glass Shelves

1. Lift up the front of the glass shelf, and then pull the shelf out.
2. Clean as needed.
3. Reinstall the shelf by placing the rear of the shelf into position first. Then, carefully lower the front of the shelf into place.

Defrosting

The appliance uses an automatic defrosting function. Frost formed due to the change of season or temperature may also be manually removed by disconnecting the appliance from the power supply or by wiping with a dry towel.

Power Failure

In case of a power failure, even in warmer weather, foods inside the appliance can be kept for several hours; during the power failure, limit the times the door is opened, and do not add more fresh food into the appliance.

Moving

- Before the unit is moved, remove all of the items stored inside, fix the glass shelves, drawers, freezing chamber drawers, etc. with tape, and tighten the leveling feet. Then, close the doors and fix them with tape.
- During moving, the appliance shall not be laid upside down or horizontally, or be vibrated; the inclination during movement shall be no more than 45°.

Vacations

- **Short vacations:** Leave the appliance operating during vacations of less than three weeks.
- **Long vacations:** If the appliance will not be used for several months, remove all items and turn the unit off. Clean and dry the interior thoroughly. To prevent odor and mold growth, leave the door open slightly, blocking it open if necessary.

TROUBLESHOOTING

You can solve many common problems easily, saving you the cost of a possible service call. Try the suggestions below to see if you can solve the problem before calling the servicer.

The unit stops working.	Check whether the appliance is connected to power or whether the plug is in well contact. Check whether the voltage is too low. Check whether there is a power failure or partial circuits have tripped.
There is an odor inside the unit.	Tightly wrap food to prevent possible odor. Check whether there is any rotten food. Clean the inside of the appliance.
The compressor runs too long.	Long operation of the compressor is normal in summer when the ambient temperature is high. It is not recommended to load a large amount of food in the appliance at one time. Cool food to room temperature before loading into the appliance. The doors are opened too frequently.
Light fails to turn on	Check whether the appliance is connected to power supply and whether the illuminating light is damaged.
Doors cannot be properly closed	The door is blocked by food packages. The appliance is not level.
Loud noise	Check whether the floor is level and whether the appliance is placed stably. Check whether accessories are placed at proper locations.
Door seal fails to be tight	Remove foreign matters on the door seal. Heat the door seal and then cool it for restoration (ex: blow it with an electrical drier or use a hot towel for heating).
Water pan overflows	There is too much food in the chamber or the food stored contains too much water, resulting in heavy defrosting. The doors are not closed properly, resulting in frosting due to the entry of air and increased water due to defrosting.
Hot housing	Heat dissipation of the built-in condenser via the housing, is normal. When the housing becomes hot due to high ambient temperatures and the storage of too much food, it is recommended to provide sound ventilation to facilitate heat dissipation.
Surface condensation	Condensation on the exterior surface and door seals of the appliance is normal when the ambient humidity is too high. Just wipe the condensate with a clean towel.
Abnormal noise	Buzz: The compressor may produce a buzzing noise during operation, and the buzzes are loud particularly upon start or stop. This is normal. Creak: Refrigerant flowing inside of the appliance may produce a creaking sound, which is normal.

If you've checked the table above and find that you still need help with your appliance, call our Customer Service facility at **800-932-4267** between 9:00AM and 5:00PM ET. We will do our best to answer your questions.

NOTES

NOTES

LIMITED WARRANTY

ONE-YEAR LIMITED WARRANTY

Within the 48 contiguous United States, for one year from the date of purchase, when this appliance is operated and maintained according to instructions attached to or furnished with the product, warrantor will pay for factory-specified parts and repair labor to correct defects in materials or workmanship. Service must be provided by a designated service company. Outside the 48 states, all parts are warranted for one year from manufacturing defects. Plastic parts, shelves and cabinets are warranted to be manufactured to commercially acceptable standards, and are not covered from damage during handling or breakage.

5-YEAR COMPRESSOR WARRANTY

1. The compressor is covered for 5 years.
2. Replacement does not include labor.

ITEMS WARRANTOR WILL NOT PAY FOR:

1. Service calls to correct the installation of your appliance, to instruct you how to use your appliance, to replace or repair fuses or to correct wiring or plumbing.
2. Service calls to repair or replace appliance light bulbs or broken shelves. Consumable parts (such as filters) are excluded from warranty coverage.
3. Damage resulting from accident, alteration, misuse, abuse, fire, flood, acts of God, improper installation, installation not in accordance with electrical or plumbing codes, or use of products not approved by warrantor.
4. Replacement parts or repair labor costs for units operated outside the United States.
5. Repairs to parts or systems resulting from unauthorized modifications made to the appliance.
6. The removal and reinstallation of your appliance if it is installed in an inaccessible location or is not installed in accordance with published installation instructions.

DISCLAIMER OF IMPLIED WARRANTIES; LIMITATION OF REMEDIES

CUSTOMER'S SOLE AND EXCLUSIVE REMEDY UNDER THIS LIMITED WARRANTY SHALL BE PRODUCT REPAIRS PROVIDED HEREIN. IMPLIED WARRANTIES, INCLUDING WARRANTIES OF MERCHANTABILITY OR FITNESS FOR A PARTICULAR PURPOSE, ARE LIMITED TO ONE YEAR. WARRANTOR SHALL NOT BE LIABLE FOR INCIDENTAL OR CONSEQUENTIAL DAMAGES. SOME STATES DO NOT ALLOW THE EXCLUSION OR LIMITATION OF INCIDENTAL OR CONSEQUENTIAL DAMAGES, OR LIMITATIONS ON THE DURATION OF IMPLIED WARRANTIES OF MERCHANTABILITY OR FITNESS, SO THESE EXCLUSIONS OR LIMITATIONS MAY NOT APPLY TO YOU. THIS WARRANTY GIVES YOU SPECIFIC LEGAL RIGHTS AND YOU MAY ALSO HAVE OTHER RIGHTS, WHICH VARY FROM STATE TO STATE.



WARNING: This product can expose you to chemicals including nickel (metallic), which is known to the State of California to cause cancer.

For more information go to www.P65Warnings.ca.gov

Note: Nickel is a component in all stainless steel and some other metallic compositions.

Felix Storch, Inc.
Summit Appliance Division
An ISO 9001:2015 registered company
770 Garrison Avenue Bronx, New York 10474
www.summitappliance.com

SUMMIT
APPLIANCE

For parts and accessory ordering,
troubleshooting and helpful hints, visit:
www.summitappliance.com/support