

**Coil Elements
Radiant Glass Top
Instructions for
Porcelain Enamel and
Continuous Cleaning
Oven Interiors**

This manual contains information for:

- **Important Safeguards**
- **Installation**
- **Use and Care**

Certain ranges come equipped with special features. Determine from a study of your range which of the instructions given in this booklet pertain to your range.

This booklet gives valuable instructions covering the installation, adjustment and use of your range.

HOW TO OBTAIN SERVICE AND/OR PARTS

When your range does not operate in accordance with the instructions in the manual, you should contact the dealer in the immediate vicinity for service. Or, the purchaser may contact the service organization noted on the warranty.

Electric Range

Read and Save These Instructions

IMPORTANT – Save for local electrical inspector's use.

Range

Record in the space provided below the Model No. and Serial No. of this appliance. These numbers are found on the serial plate located below the lift-up cooktop.

Model No. _____ Type Number _____

Serial No. _____ Purchase Date _____

Record these numbers for future use.

IMPORTANT: Keep a copy of your bill of sale. The date on the bill establishes the warranty period should service be required. If service is performed, it is in your best interest to obtain and keep all receipts.

PLEASE DO THIS NOW!

The PRODUCT REGISTRATION CARD should be filled in completely, signed and returned. This information will register your product and help us to serve you quickly in the future if necessary.

Contents

Important Safeguards3-7

Energy Saving Ideas.....7

Installation Instructions8-12

Backguard Installation Instructions9

Cabinet Preparations13

Surface Cooking.....14-15

Oven Operation16

Optional Equipment17-18

Radiant Glass Top19

Care of Your Range.....20-22

Alignments and Adjustments23

Lift-Off Door.....24

Wiring Diagrams-Electrical25-33

Built-In Wall Ovens26

Built-In Cooktops.....29

Note: For warranty and service information, please see attachments packaged with range.



California Proposition 65B

Electric cooking appliances could produce or may contain some products which are on a list of substances known by the State of California to cause cancer or reproductive harm. California law requires businesses to warn customers of potential exposure of such substances. To minimize exposure to these substances, always install, operate, and maintain this product according to the “use and care” manual.

READ THE IMPORTANT SAFEGUARDS AND ALL INSTRUCTIONS BEFORE USING THE APPLIANCE.

Remove all tape and packaging wrap before using the oven. If any glue remains, touch the residue with the sticky side of the tape already removed. Or, use a cloth soaked with rubbing alcohol. Use caution because rubbing alcohol is flammable. Rinse with warm water and wipe dry.

Destroy or recycle the carton and plastic bags after the range is unpacked. Children should not use packaging material for play. Cartons covered with rugs, bedspreads, or plastic sheets can become air-tight chambers. Remove all staples from the carton. Staples can cause severe cuts and destroy finishes if they come in contact with other appliances or furniture.

Besafety conscious. The preparation of food in an oven requires temperatures that could cause severe burns. Before using this new appliance, carefully read and follow all instructions.



The California Safe Drinking Water and Toxic Enforcement Act of 1986 (Proposition 65) requires the Governor of California to publish a list of substances known to the State of California to cause cancer or reproductive harm. In addition, businesses must warn customers of potential exposure to such substances.

Users of this appliance are hereby warned there may be some low level exposure to some of the listed substances including acrylamide and carbon monoxide. This happens when the oven, if equipped with a self-clean feature, is engaged in a self-clean cycle. Exposure to these substances can be minimized by properly venting the oven, especially during the self-cleaning cycle, by opening a window or using a ventilating hood or fan.

Notice: Never keep pet birds in the kitchen. Birds have a very sensitive respiratory system. Fumes released during the self-cleaning cycle, overheated cooking oil, fat, margarine or overheated non-stick cookware may be harmful or fatal to birds.

PROPER INSTALLATION: Be sure your appliance is properly installed and grounded by a qualified technician in accordance with the National Electrical Code ANSI/NFPA NO. 70-latest edition and local electrical code requirements. Install only per installation instructions provided in the literature package for this range. Be sure leveling legs are in place at the bottom corners of the range. If necessary, raise or lower the leveling legs at the base of the range by turning clockwise or counterclockwise to insure a level range.

Ask your dealer to recommend a qualified technician and an authorized repair service. Have the technician label the proper switch or fuse at the electrical disconnect box and show you how to disconnect the power to the range at the circuit breaker or fuse box in case of an emergency.



The following situations may cause serious bodily harm, death or property damage.

- **TO REDUCE THE RISK OF TIPPING OF THE RANGE, THE RANGE MUST BE SECURED BY A PROPERLY INSTALLED ANTI-TIP BRACKET PROVIDED WITH THE RANGE. TO CHECK IF THE DEVICE IS INSTALLED AND ENGAGED PROPERLY, CAREFULLY TIP THE RANGE FORWARD. THE ANTI-TIP DEVICE SHOULD ENGAGE AND PREVENT THE RANGE FROM TIPPING OVER. REFER TO THE INSTALLATION INSTRUCTIONS PACKAGED WITH THE ANTI-TIP BRACKET FOR PROPER ANTI-TIP BRACKET INSTALLATION.** A child or adult can tip the range. Verify the anti-tip device has been properly installed and engaged. Do not operate the range without the anti-tip device. Failure to do so can result in death or serious burns.
- **Never leave children alone or unattended in the area where an appliance is in use.** They should never be allowed to sit or stand on any part of the appliance. Never leave the oven door open when the range is unattended.

IMPORTANT SAFEGUARDS, Continued

- **Do not store items of interest to children in the cabinets above a range or on the backguard of a range.** Children climbing on the range to reach the items could be seriously injured.
- **Do not allow children to climb or play around the range.** The weight of a child on an open oven door may cause the range to tip, resulting in serious burns or other injury.
- **USER SERVICING: Do not repair or replace any part of the appliance unless it is specifically recommended in this owner's guide.** To prevent personal injury and damage to the range, servicing should be done only by a qualified technician.
- **Storage in or on appliance:** Flammable materials should not be stored in an oven, near surface elements or in the storage drawer (some models). This includes paper, plastic and cloth items, such as cookbooks, plastic ware and towels, as well as flammable liquids. Do not use the oven for storage. Do not store explosives, such as aerosol cans, on or near the range.
- **Remove the oven door from any unused range if it is to be stored or discarded.**
- **Stepping, leaning or sitting on the doors or drawers of this range can result in serious injuries and cause damage to the range.**



The following situations could cause bodily injury or property damage.

- **DO NOT TOUCH SURFACE UNITS, AREAS NEAR THESE UNITS, OVEN HEATING ELEMENTS OR INTERIOR SURFACES OF THE OVEN UNTIL THEY HAVE COOLED.** Both surface elements and oven heating elements may be hot even though they are dark in color. Areas near surface units and interior surfaces of the appliance may become hot enough to cause burns—these areas include the cooktop, surfaces facing the cooktop and the oven vent openings, and surface near these openings, oven doors and windows.
- **Make sure the reflector pans are always in place under the surface elements.** This avoids possible damage to wiring or components underneath and improves cooking efficiency.
- **It's good practice for each household to have an appropriate fire extinguisher** for use in the event of a house fire.



- **NEVER use this appliance as a space heater to heat or warm the room.** Operating surface elements at the HIGH setting without pots or pans on the elements, could damage the range and result in fire.
- **Wear proper apparel when operating the range.** Loose fitting or hanging garments should never be worn while using the appliance. Do not let clothing or other flammable materials contact surface elements or interior surfaces of the oven until they have had sufficient time to cool.

IMPORTANT SAFEGUARDS, Continued

- **Never modify or alter the construction of the range** such as removal of leveling legs, panels, wire covers, anti-tip brackets or any other permanent part of the product.
 - **Stand to the side of the oven when opening the oven door.** Slowly open the door to allow hot air or steam to escape before removing or replacing food.
 - **Keep children from touching the oven door (or glass window, if equipped) when the range is operating** as the door (or window) could get hot enough to cause serious burns.
 - **When heating fat or grease, watch it closely.** Fat or grease may catch fire if allowed to become too hot.
 - **Do not use water or flour on grease fires.** Smother the fire with a pan lid, baking soda or use a dry chemical or foam-type extinguisher.
 - **Use only dry potholders.** Wet or damp potholders on hot surfaces could result in burns from steam. Do not let the potholder touch hot heating areas. Do not use a towel or other bulky cloth instead of a potholder.
 - **Turn utensil handles inward, but not extending over other surface elements.** This will minimize the possibility of burns, ignition of flammable materials, and spillage due to accidental contact with the utensil.
 - **Never immerse or soak the removable surface elements in water.** Surface elements clean themselves during normal operations or can be wiped with a damp, sudsy cloth when the elements are off and cool. Be sure the elements are off and cool before touching them. Even when the elements appear dark in color, they may be hot.
 - **Never leave the range unattended while the surface elements are on.** Boil overs may cause smoking, greasy spill overs may catch fire or a pan which has boiled dry may melt.
- 
- **Do not use aluminum foil to line the surface element reflector pans and never cover an entire oven rack with aluminum foil.** Improper use of aluminum foil may result in shock or fire hazard. Refer to the Cleaning section of this manual for more information on the use of aluminum foil.
 - **Do not use glass, earthenware or other ceramic-type cooking utensils for range top cooking unless recommended by the utensil manufacturer.** Utensils of this type may break with sudden heat changes; most are designed to be used only in the oven.
 - **Do not use plastic salt and pepper shakers, spoon holders or plastic wrappings on top of the range when it is in use.** These items could melt or ignite. Potholders, towels or wooden spoons could catch fire if placed too close to the element.
 - **Do not place hands between the spring tension hinge and the oven door frame when you are removing the oven door.** You could pinch your fingers.

IMPORTANT SAFEGUARDS, Continued

- **Do not heat unopened food containers.** Build-up of pressure may cause the container to burst and result in injury.



The following situations could cause bodily injury or property damage.

- **Disconnect the range from electrical supply before attempting to service or move it.**
- **Do not use a wok on the cooking surface if it is equipped with a round metal ring that extends beyond the bottom element.** Because this ring acts as a heat trap, it may damage the heating element, the surface cooking finish and the chrome pans under the element.
- **Do not touch a hot oven light bulb with a damp cloth.** Doing so could cause the bulb to break and may cause steam burns. Disconnect the electrical service cord or shut off the power to the oven before removing and replacing the bulb.
- **Allow parts to cool to room temperature before touching or removing them from the range.** When a surface element is first turned off, the element is still hot enough to cause burns.
- **Know which knob controls each element.** Place a pan of food on the element before turning it on, and turn the element off before removing the pan.
- **Do not use the broiler pan without its insert.** Do not cover the insert with foil. Exposed fat or grease could ignite. The broiler pan and its insert allow dripping fat to drain and be kept away from the high heat of the broiler.
- **Do not allow dry, empty pans to cook on the heating element** as this could ruin both the pan and the heating element.
- Clean the range regularly to keep all parts free of grease which could catch fire. Pay particular attention to the area underneath each surface element. Exhaust fan ventilating hoods and grease filters should be clean. Do not allow grease to accumulate. Greasy deposits in the fan could catch fire. Refer to the hood manufacturer's instructions for cleaning.
- **Always place an oven rack in the desired location while the oven is cool.** If a rack must be moved when the oven is hot, use potholders and grasp the rack with both hands to reposition. Do not let potholders contact the hot heating element in the oven.

Continuous Cleaning Ovens Only:

- **Do not use oven cleaners.** No commercial oven cleaner or oven liner protective coating of any kind should be used in or around any part of the continuous cleaning oven.
- **This product is only to be used for the purpose of cooking food.** Do not use this cooking product in any way other than it is intended. It is not to be used to process laundry, ignite fireworks or pyrotechnic displays, or produce illegal substances banned by law, or perform any other non-cooking related function that may be deemed reckless in nature.

IMPORTANT SAFEGUARDS, Continued

- **Use care when touching glass top.** The glass cooking surface will retain heat after the controls have been turned off. Make sure all surfaces have cooled before touching or cleaning.
- **Do not cook on a broken glass top.** If the top glass surface should break, cleaning solutions and spillovers may penetrate the broken glass and create a risk of electric shock. Contact a qualified service technician immediately.
- **Avoid scratching the glass top.** Avoid using knives and sharp instruments around the cook top. Do not drag or slide cookware across the glass surface.

NOTE: The instructions appearing in this owner's guide are not meant to cover every possible condition and situation that may occur. Common sense and caution must be practiced when operating and maintaining any appliance.

VENTILATING HOODS

Clean Ventilating Hoods Frequently

Grease should not be allowed to accumulate on hood or filter. When flaming foods under hood, turn hood fans on.

ENERGY-SAVING IDEAS

Surface Cooking

Turn surface elements off before cooking is completed. The units will stay hot long enough to finish the cooking process.

Use lids when surface cooking. A lid traps steam and uses it to speed up the cooking process. If you have a pressure cooker or vegetable steamer, use it. You'll waste fewer vitamins, save time and cut energy costs.

Use medium-weight, flat bottomed pans that match the sizes of the elements. Pick pans made of a metal that conducts heat well.

When cooking on a surface element, use as little water as possible to reduce cooking time. Never use the range to heat the kitchen. Using your range without utensils or pans to absorb the element's heat risks damaging the surface and the controls.

Oven Cooking

Preheat the oven only when a recipe tells you. Put roasts and casseroles into a cold oven and then turn the oven on.

Opening the oven door often to check on foods wastes electricity.

Use the oven to prepare complete meals. For instance, start a roast, add vegetables when the meat is half-cooked, and then warm rolls or dessert after the main dishes are cooked. Thaw frozen foods before cooking. Thawed food requires less cooking energy than frozen food.

Make it a habit to turn the oven off before you remove the cooked food from it.

INSTALLATION INSTRUCTIONS

Be sure appliance is properly installed and grounded by a qualified technician.

It is the responsibility of the technician to make certain that your range is properly installed. Situations caused by improper installation are not covered under the warranty. Any expenses incurred due to such situations will not be paid by the manufacturer of the appliance.



To reduce the risk of tipping the appliance by abnormal usage or

improper door loading, the appliance must be secured by properly installing the anti-tip device packed with the appliance. To check if the device is installed and engaged properly, carefully tip the range forward. The Anti-Tip device should engage and prevent the range from tipping over.

See instructions packaged with the anti-tip device. These are packaged within the oven during shipment of the range.

If this range is removed for any reason, service or cleaning, etc., it must be replaced as outlined in the installation instructions before placing the range back in operation.

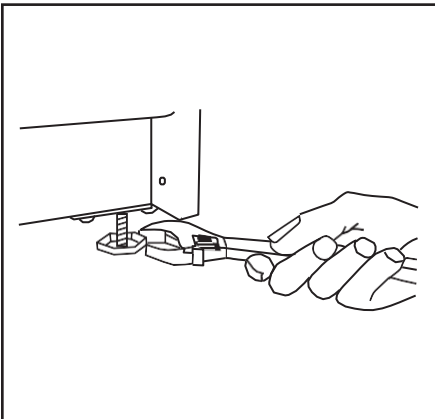

Leveling a Free-Standing Range

All free-standing ranges must be level to obtain proper cooking results. The leveling legs should be screwed into the corner brackets. Place a pan or a measuring cup partially filled with water or spirit level on oven rack. Adjust leveling legs until the range is level. The top of the side panels should be level with countertop or work surface.

IMPORTANT: Be sure to keep the leg levelers. Leveling of the range is very important.

BACKGUARD INSTALLATION INSTRUCTIONS

Electric Ranges

1. Move the main top forward. (Lift up and pull forward slightly.) For glass top models, rear holding brackets will have to be briefly unscrewed then reattached when backguard installation is complete.
2. Place the backguard on top of end panels at the rear of range. Make certain the tabs of the burner box cover rest on the outside of the burner box flanges. (See No. 1.)
3. If backguard is equipped with electrical features, connect the corresponding black and white wires then tuck them into the connection channel. (See No. 2.)
4. Insert machine screws through lower inside flange of end caps and end panels. Secure with hex nuts provided. (See No. 3.)
5. Insert machine screws through elongated holes at bottom of backguard and side flanges of burner box. Secure with hex nuts provided. (See No. 4.)
6. Attach wire connection channel to the main back wire cover. Use the sheet metal screw provided. (See No. 5.)

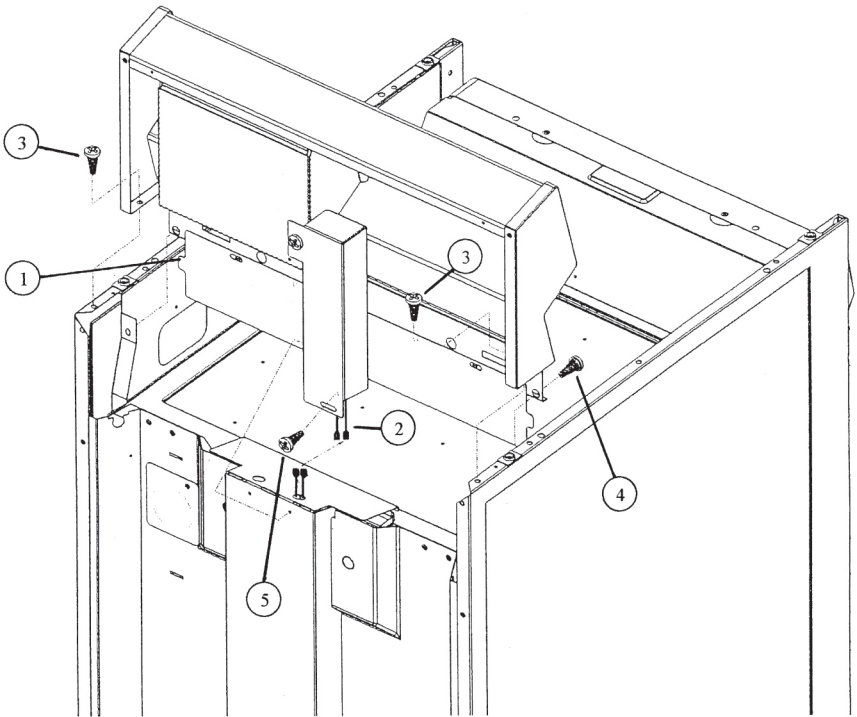

Power Connections to Appliances

Have the range installed by a qualified service technician or an authorized servicer. Installation must conform with the National Electric Code ANSI/NFPA NO. 70-latest edition and local electrical code requirements.



Be sure electric power is OFF at the fuse (breaker) box until the unit is installed and ready to operate. See appliance rating plate for maximum K.W. and amperage rating.

CORD CONNECTED APPLIANCES

We recommend that you have the electrical hookup of your range done by a qualified electrician. Have the electrician show you where your range disconnect is located. If you fail to wire your range in accordance with governing codes, you may create a hazardous condition.

Refer to the rating plate for electrical requirements. The rating plate is located in the burner box area on freestanding ranges and cook tops. Lift up the front edge of the main top to find the rating plate. On built-in wall ovens and glass top ranges, the plate can be found in the storage compartment. Open the storage door panel to find the rating plate.

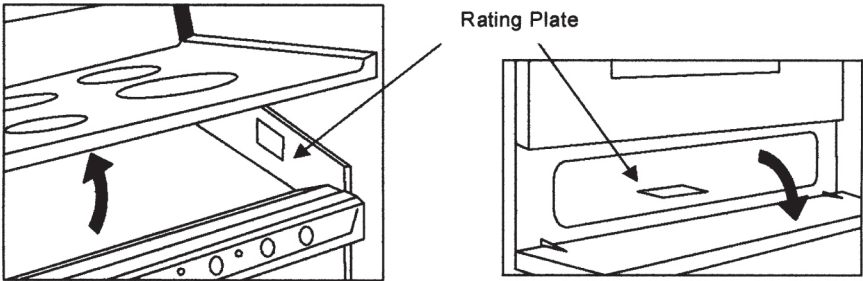

You must use a three-wire, single-phase AC 208/240 Volt, 60 Hertz electrical system to operate your range. Use #8 wire and 40 Amp fuse or circuit breaker for 240 Volt and 208 Volt systems.

For ranges equipped with a terminal block, use only a 3-conductor or 4-conductor UL listed 40 Amp 125/250 minimum volt electric range power cord. The cord must have open end spade lugs with upturned ends or closed loop terminals. An appropriate strain relief bracket must be provided on the power cord. Power cord strain relief must be used.

It is strongly suggested that your electric range be connected by means of a cord utilizing **copper conductors**. Copper has always proven itself to be the most dependable conductor. However, many homes may be wired to connect to a range by means of aluminum wiring. This is not an ideal situation, and we urge you to have a qualified electrician change to a copper cord connection. If this is not possible, bare wire connections can be made with the terminal adaptor kit packed in with the range.

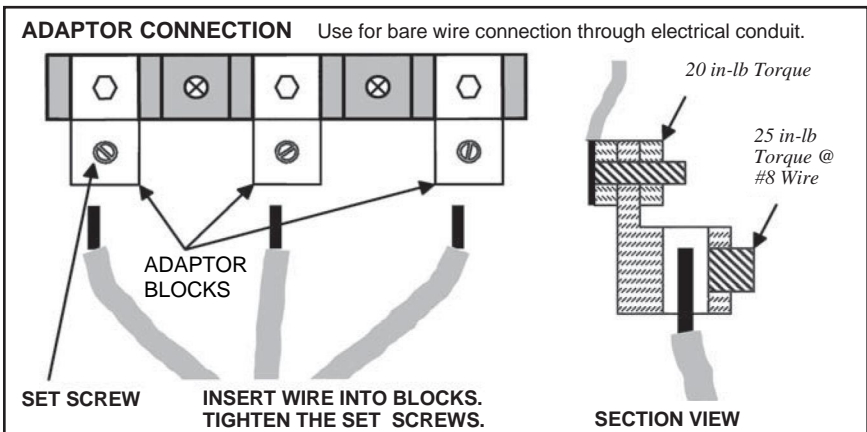

THREE-WIRE CORD CONNECTION

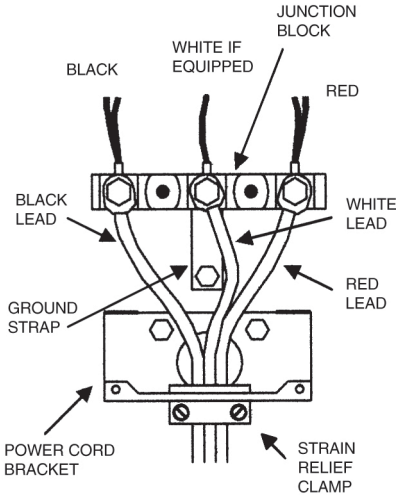

120/240 or 240 VAC

1. Remove the top nuts on the junction block studs.
2. Tighten the back nuts.
3. Install the three-wire cord and strain relief provided on the cord set through the hole in the power cord bracket.
4. Connect the red and black leads to the outer terminals and the white lead to the center terminal. Use the topnuts removed earlier in step 1.
5. Push the cord upward (to relieve strain) while tightening the strain relief clamp.

If local codes do not allow grounding through the neutral, refer to the illustration below of FOUR-WIRE CORD CONNECTION.

FOUR-WIRE CORD CONNECTION

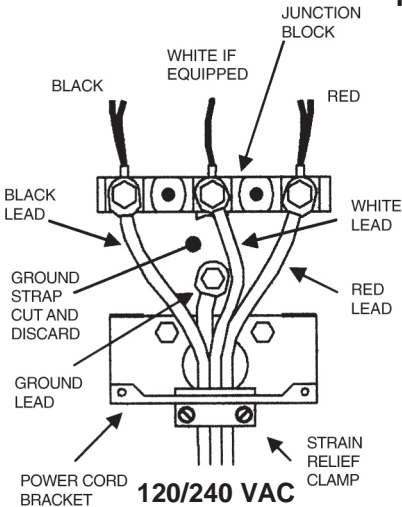

120/240 VAC

1. Remove the top nuts on the junction block studs.
2. Tighten the back nuts.
3. Remove the green ground screw and cut off the ground strap as close to the junction block as possible.
4. Remove the ground strap.
5. Install the four-wire cord and strain relief provided on the cord set through the hole in the power cord bracket.
6. Connect the red and black leads to the outer terminals and the white lead to the center terminal. Use the top nuts removed earlier in step 1.
7. Connect the ground lead below the junction block with the ground screw that was removed earlier in step 3.
5. Push the cord upward (to relieve strain) while tightening the strain relief clamp.

Effective January 1, 1996 the National Electrical Code requires that new construction (not existing) utilize a 4-conductor connection to an electric range.

NOTE: A 4-conductor cord is to be used when the appliance is installed in a mobile home or when local codes do not permit grounding through the neutral.

THREE-WIRE CONDUIT CONNECTION

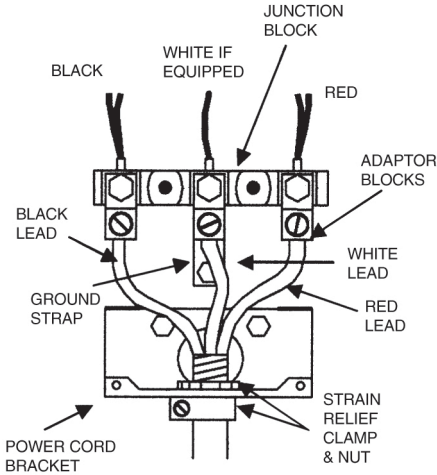

120/240 or 240 VAC

If local codes do not allow grounding through the neutral, refer to the illustration below of **FOUR-WIRE CONDUIT CONNECTION**.

NOTE: The power cord bracket will have to be reversed for conduit installations. Detach the bracket and flip its orientation. Reattach the bracket to the range so the conduit will pass through the smaller hole.

1. Remove the top nuts on the junction block studs.
2. Tighten the back nuts.
3. Install the terminal adaptor blocks for bar wire connection. Use the top nuts removed in step 1.
4. Install the three-wire conduit and an appropriate strain relief clamp through the hole in the power cord bracket.
5. Insert the red and black leads into the outer blocks and the white lead into the center block. Tighten the set screws.
6. Secure the strain relief clamp around the conduit and tighten the nut against the power cord bracket.

FOUR-WIRE CONDUIT CONNECTION

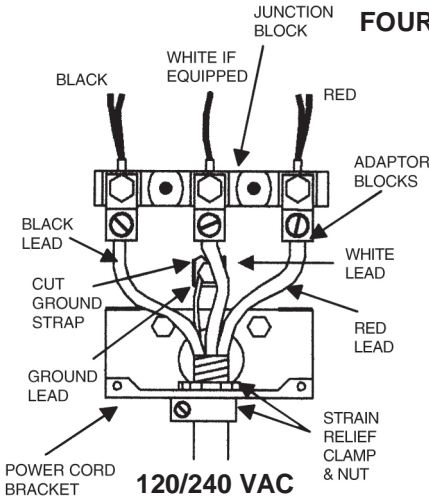

120/240 VAC

Effective January 1, 1996 the National Electrical Code requires that new construction (not existing) utilize a 4-conductor connection to an electric range.

NOTE: A 4-conductor connection is to be used when the appliance is installed in a mobile home or when local codes do not permit grounding through the neutral.

NOTE: The power cord bracket will have to be reversed for conduit installations. Detach the bracket and flip its orientation. Reattach the bracket to the range so the conduit will pass through the smaller hole.

1. Remove the top nuts on the junction block studs. Then, tighten the back nuts.
2. Cut the ground strap as close to the junction block as possible and at the lower section with upturned sides.
3. Install the four-wire conduit and an appropriate strain relief clamp through the hole in the power cord bracket.
4. Use the section of ground strap with upturned sides and the ground screw to connect the ground lead below the junction block.
5. Install the terminal adaptor blocks for bar wire connection. Use the top nuts removed earlier in step 1.
6. Insert the red and black leads into the outer blocks and the white lead into the center block. Tighten the set screws.
7. Secure the strain relief clamp around the conduit and tighten the nut against the power cord bracket.

CABINET PREPARATIONS

Free-Standing Ranges

“A” - 30 inches minimum clearance between the top of the cooking surface and the bottom of an unprotected wood or metal cabinet; or

“A” - 24 inches minimum when bottom of wood or metal cabinet is protected by not less than 1/4 inch “Flame Retardant” millboard covered with not less than No. 28 MSG sheet steel, 0.015 inch stainless steel, 0.024 inch aluminum or 0.020 inch copper.

“B” - Make opening between cabinet as shown in drawings. Level range so the main top is level with the cabinet top. Make electrical connection and slide range into opening.

RANGE SIZE	“B” DIMENSION	“C” DIMENSION	“C” = Inches from combustible vertical walls above cooking surface.
20”	20 3/8”	2”	
24”	24 3/8”	0”	
30”	30 3/8”	0”	
36”	36 3/8”	0”	

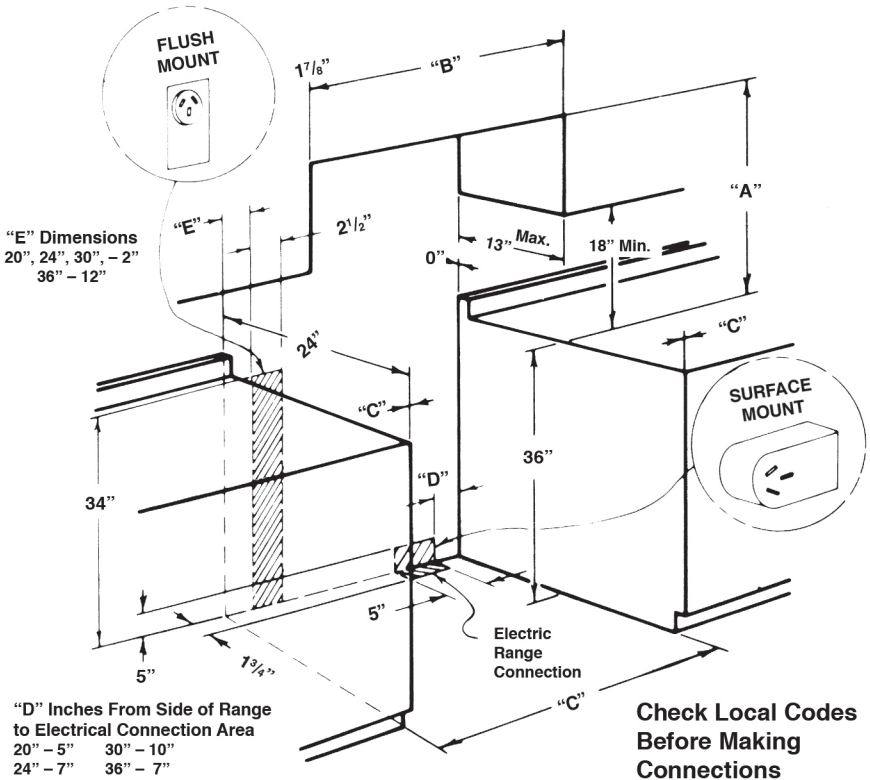

To eliminate the hazard of reaching over the heated surface units, cabinet storage space located above the surface units should be avoided. If cabinet storage is to be provided, the hazard can be reduced by installing a range hood that projects horizontally a minimum of 5 inches beyond the bottom of the cabinets.

SURFACE COOKING

Cooking Utensils

Your range is equipped with tubular type top elements. Here are some helpful hints for successful cooking.

For best result and energy conservation, choose cooking utensils which have the following characteristics:

- Pans should have **flat bottoms** that make good contact with the entire element. Check for flatness by rotating a ruler across the bottom. There should be no gaps between the pan and the ruler.
- Pan sizes should **match the size of the surface element**. Large pans and skillets should be used on a large element. Smaller pans should be used on a smaller element. Pans should cover the entire element to absorb the maximum heat. Avoid using an undersized utensil which would expose a portion of the element. This could result in dangerous direct contact with a hot element, resulting in serious burns or clothing ignition. The size of the pan should also suit the amount of food being prepared.



Do not use extremely large pans that extend more than one inch over the edge of the surface element and touch the range surface. **Do not use two surface elements to heat one large pan such as a roaster or griddle.** The bottom surface of the pan in either of these situations could trap enough heat to cause discoloring of the drip pans, damage to the surface elements and/or crazing (fine cracking) of the porcelain enamel range surface.

- Pans should be **well-balanced** so that handles do not cause them to tilt.
- Pans should have **tight-fitting lids** to hold steam within the pans and reduce cooking time. Lower heat settings may be used when pans are covered with lids.
- Pan materials should have **good heat conduction**. Medium-weight aluminum gives good results for most cooking. The chart on page 13 gives suggestions for best results when cooking with a variety of pan materials.
- **Specialty pans**, such as woks, lobster pots, griddles and pressure cookers, must also have flat bottoms and conform to cookware requirements.
- To heat, cookware bottoms must be in **direct contact with the element**. Do not use wire trivets or warped cooking utensils. Glass cooking utensils are also not recommended since they are poor conductors of heat.
- **To avoid spattering** and to maximum efficiency, pan bottoms should be clean and dry before coming in contact with the elements.
- **Wipe spills off the elements** with a damp cloth as soon as they cool to cut down on clean up time. Be sure the control is "off."

SURFACE COOKING, continued

Cooking Utensils, Continued

Material	Characteristics	Uses
Aluminum	Excellent conductor of heat. Available in various gauges.	All foods. With thin gauge, cook with some liquid. Thicker gauges are suggested for frying, candy and sauces.
Cast iron	Heats unevenly unless used with low heat. Holds heat. Subject to rust. Used for skillets and Dutch ovens.	Suggested for foods that require long, slow cooking. Use medium or low heat to preheat and brown foods.
Ceramic/glass	Relatively poor heat conductor. Holds heat well. Subject to chipping.	Use for long, low heat cooking with liquids.
Enamel ware	Relatively poor heat conductor. Subject to chipping.	Use only with large quantities of liquid.
Stainless steel, clad and inner core	Plain stainless steel is a relatively poor heat conductor. It is often combined with other materials, either on the bottom or in an inner core, to improve heat transfer. Easy to clean.	Plain stainless steel should be used only with large quantities of liquid. Pans with other metals can be used for all cooking.

**Caution: Permanent damage will take place if cookware fuses to the element.*

To Operate Surface Units

The surface controls are easily operated. Simply push in and turn in either direction. When the element is energized, the indicator light (cook top signal light) glows when one or more of the elements is turned on.

The infinite switch has a variety of heat settings from low to high. The range of heat is increased by turning the knob to "high."



Do not use aluminum foil to line the surface element reflector pans. Improper use of aluminum foil may result in shock or fire hazard. Foil may also interfere with heat circulation and damage the range. 11-97

OPERATIONAL CHECK

Check all connections to see that they are tight and have not become loosened during transit. Each top element is controlled by a switch and when turned on the element should heat up within a minute except for solid disk elements. These take approximately 3 minutes. (Solid elements do not get red in color when hot.) The oven bake element should heat up within a minute when the temperature control is set in the bake area of the dial. The broil element can be checked with dial in broil mode. With dial at 400°F, temperature should be reached within 10-12 minutes. The elements are covered with a protective coating of oil. When heated up for the first time, open the oven door and allow the thermostat to operate at 400°F for about 10 minutes. This should evaporate the oil, and dissipate odors and possible smoke caused by the burning off of this protective coating.

OVEN OPERATION

Opening Oven Door

Let hot air or steam escape before removing or replacing food.

Arranging Oven Racks

Always arrange the oven racks while the oven is cool. To remove the rack, pull forward until it stops. Lift up the front and slide out. To replace, fit the rack onto the guides on the oven walls. Tilt the front of the rack upward and slide back into place. Place the racks so the food is “centered” in the oven.

When more than one utensil is used, be sure to stagger them allowing space between each one. Don't allow the utensils to touch any part of the oven, especially the glass window. It is best to use both racks equipped with the oven, and place food so one utensil is not directly over another.

Baking

By using the latest development in an electric oven heat control, a fast bake temperature is obtained. However, preheating the oven for 10-12 minutes is recommended so the oven can cycle properly before baking. Turn oven control clockwise to the temperature setting of your choice. An indicator light will glow when there is electric power to the bake element. When the oven temperature setting is reached, the indicator light will go off. It lights up again when the power comes back on the bake element.

Broiling

Broiling may be slightly different from any previous broiling you may be acquainted with, so be sure to read this section completely.

To broil, turn the temperature control knob clockwise to the “BROIL” position. This action makes a switch in the oven thermostat engage the broiling element. Turning the temperature knob away from this position will switch the thermostat back into bake mode.

Always broil with the oven door closed. The oven temperature control will maintain the oven temperature while your food is broiled.

For most instances, the top oven rack position can be used for broiling. If broiling with lower heat is needed, the second rack position from the top can be used. Lower rack positions can be used for even lower broiling intensity.

SELECT THE OVEN RACK POSITION BEFORE YOU BEGIN BROILING.

OPTIONAL EQUIPMENT

Continuous Cleaning Feature

If your oven has the continuous cleaning feature, it will have a dull gray finish with white speckles that has been blended with a special catalytic material. (If the oven has a glossy finish, it is standard porcelain enamel without the continuous cleaning feature.)

Before Using Your Oven—Read These Instructions Carefully.

Using The Continuous Cleaning Oven

The catalytic finish will keep your oven presentably clean with some effort on your part. Any time the oven is in use, the catalytic action will be working to eliminate normal cooking spatters. Simply cook as you usually do. Average oven spatters should fade away. If a great deal of spattering occurs during cooking, a small amount may remain on the surface of the oven interior at the end of the cooking time. This is particularly true during a short cooking cycle. The longer the cooking cycle, the better the catalytic action.

Cleaning time depends on the type, size and amount of soil, and oven temperature. The cleaning time will vary from a few minutes to several hours. The oven will never get completely clean—it will appear “presentably clean,” even though some stains or spatters may be present.

Heavy Spill overs—Unusual Stains

The continuous cleaning oven feature will make cleanups easy. However, some spills or food types are harder for the oven to clean without a little assistance. For heavy spill overs, such as from an overfilled fruit pie or casserole, put a cookie sheet or aluminum foil on the oven bottom. Be sure the foil does not touch the element or extend beyond it.

If you should get a heavy spillover on the oven bottom:

1. Brush off heavy soil with a nylon brush or plastic pad. **DO NOT USE** paper toweling, cloths or sponge. Oven walls are porous and particles of these materials will rub off on walls. Rinse area well with clean water only. Do not allow insulation under oven bottom to become wet.
2. If spillovers harden before they can be wiped away, they may become either a brittle crust or a varnish-type coating. The brittle crusts will loosen and flake off in time. This process can be speeded up by **GENTLY** tapping crust with a wooden or plastic utensil and then brushing crust away.
3. Any remaining soil will gradually reduce with continued oven use at normal baking temperatures.

DO NOT USE ANY TYPE OF OVEN CLEANER, POWERED CLEANSERS, SOAP, DETERGENT OR PASTE ON ANY CONTINUOUS CLEANING SURFACE. ALSO, DO NOT USE ANY ABRASIVE MATERIALS, STEEL WOOL, SHARP INSTRUMENTS OR SCRAPERS. THEY WILL DAMAGE THE FINISH.

NOTE: Over a period of time, wear marks may appear on the embossed rack supports. This is normal and results from sliding the oven racks in and out of the oven. Wear marks will not interfere with the overall cleaning action of the oven.

OPTIONAL EQUIPMENT, continued

Background and Control Panel Features



Electrical Grounding Instructions: This Appliance must be properly grounded and must be connected as shown in figure 1, 2 or 3 on page 11. Do not alter wiring or electrical equipment.

The backguard equipment is optional, depending on model selection. The range you have purchased may or may not be equipped with the features that are illustrated in this section. The clocks have been placed into separate groups.

DIGITAL CLOCK WITH TIMER

To set “time of day” press **CLOCK**. Press ▲ or ▼ to set correct time.

To set “cook time” press **TIMER** (0:00 WILL APPEAR). Press ▲ to set minutes (12 HRS IS MAXIMUM TIMER SETTING). Then press **TIMER** again.

Colon starts blinking indicating timer is counting down.

To clear timer press **TIMER**.

To return to clock while timer is running, Press **CLOCK**.

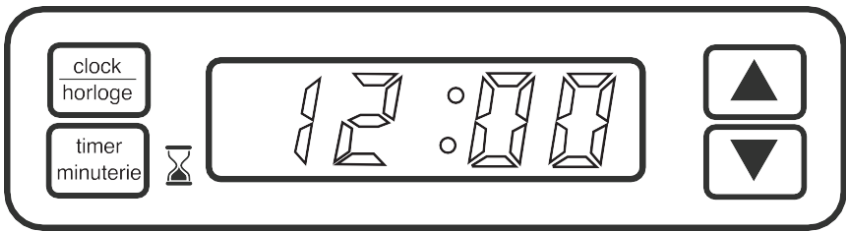

RADIANT GLASS COOK TOP

Models with radiant cook top features are equipped with heating units beneath a smooth glass cooking surface. It is important to care for the radiant cook top as outlined in the sections below.

Cookware

Select cooking utensils to use that are in good condition and have a flat bottom surface. Warped or curved pans will not make good contact with the glass surface resulting in poor performance. Cookware in poor condition also increases the risk of scratching and damage to the glass.

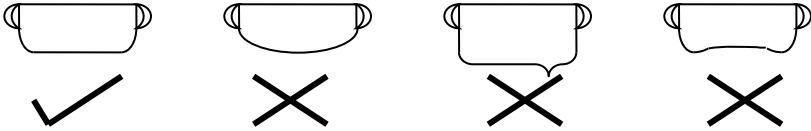

Some types of cookware materials are not recommended for use on glass cook tops. Cookware made of stainless steel is most suitable. Cookware made of heavy weight aluminum or copper also works well. However these materials can leave residue that will need to be cleaned once the glass surface has cooled after cooking. Ceramic cookware is **not recommended** because of its poor heat conductivity and risk of scratching the glass. Stoneware and cast iron cooking utensils pose a high risk of scratching the glass and are **not recommended**.

Never cook food directly on the glass surface. Always use cookware

Temperature Limiter

Each heating zone has a temperature limiter to help protect the longevity and usefulness of the glass cook top. There are many good cooking practices that you can do to preserve the livelihood of the glass as well.

1. Keep pots and pans centered over the heating zone. Operating the cook top with part of the heating element uncovered and exposed wastes energy and makes the glass temperature rise higher than in normal cooking.
2. Do not allow pans to boil dry. This could also cause the glass to reach higher than normal temperatures and could damage your cookware.
3. Do not drag or slide cookware across the glass surface. This will lead to scratches to the glass surface.
4. Do not store heavy items in overhead cabinets above the cook top. If accidentally dropped, there is a risk of breaking the glass surface.
5. Do not place wet pans on the cooking glass. The moisture will boil away and possibly leave stains on the glass.
6. Use extra care when cooking with sugary substances such as jellies, fudge, candy, etc. If spilled and allowed to cool on the glass, these could result in permanent pitting of the surface (not covered under warranty). If such a spill occurs, turn off all heating zones and remove the cookware. Put on dry oven mitts that are in good condition and carefully wipe up the spill with dry paper towels. Take as much precaution as possible to not make direct skin contact with the glass when doing this as the surface will still be very hot from cooking.
7. Do not leave plastic or rubber utensils such as spatulas or stirring spoons on the glass. These could melt and cause permanent pitting of the surface.

CLEANING THE RANGE

Always keep cleaning materials and chemicals in a safe place and away from children. Know what you are using. Make sure all parts of the range are COOL before cleaning. Be sure to replace the parts correctly.

Using Commercial Oven Cleaners

Commercial oven cleaners may be used on porcelain lined ovens; however, many cleaners are very strong, and it's essential to follow instructions carefully.

Oven cleaners can coat or damage the thermostat sensing device (the long tube in the oven) so that it will not respond to temperature accurately. If you use an oven cleaner, do not let it contact the sensing bulb, or any chrome, aluminum, or plastic part of the range. **Do not apply or allow the cleaner to come in contact with any parts or surfaces other than the oven interior.**

Do not use harsh cleaners or degreasers on or around functional parts. This will damage or drastically reduce the life of the part.

After using such cleaners, thoroughly rinse the oven with a solution of 1 tablespoon vinegar to 1 cup of water.

Use only a mild solution of soap and water on **backguards, aluminum control panels and painted surfaces**. Never use harsh abrasives or cleaning powders that may scratch or mar the surface. Make sure the cleaners and cleaning materials are suitable for use on the area to be cleaned. Always keep cleaning materials in a safe place.

Knobs

Pull forward on the knobs to remove them. Wash in a water solution with a mild detergent mix. Do not use an abrasive cleaner or any abrasive action. Abrasive action will scratch away the knob markings.

If the knobs become loose on the stem, spread the spring slightly with a small screwdriver.

Tops

The porcelain finish top can be cleaned with detergent and warm water. A mild glass wax can be used to shine the top.

Range tops finished in brushed chrome should be wiped clean after each use. Clean with a paper towel or a damp cloth. For heavy spatters, use a mild detergent and water. Then, wipe dry with a soft cloth.

A thin coating of vegetable oil should be applied periodically to the chrome top surface and underside. This will help prevent moisture from penetrating the chrome surface.

CLEANING THE RANGE, Continued

Radiant Glass Cook Top

Before attempting to clean the glass of the radiant cook top, make sure all surfaces have cooled down after cooking operations have been completed. When in use, a “HOT SURFACE” light will illuminate as a helpful reminder. This light will stay illuminated for several minutes after cooking has been completed even if controls have been turned off. Always be alert to the presence of hot surfaces on your cooking appliance.

For normal use cleaning, we recommend using Weiman® or Cerama Bryte® glass cleaner for the best cleaning results. Do not use harsh abrasives or rough scouring pads to attempt to clean the glass. Permanent scratching could result.

1. Shake the container of glass cleaner well before using.
2. Apply a few drops of the cleaner cream directly to the glass surface.
3. Use a paper towel or cleaning pad designed for glass cooking surfaces to clean the entire cook top area.
4. Use a dry cloth or paper towel to remove all cleaning residue. There is no need to rinse with water, but be sure all cleaning residue has been removed before resuming use of the cook top.

For heavy, burned on spillover material, a razor blade scraper can be used to very carefully scrape off the glass as follows.

1. Allow the cook top to cool completely to room temperature.
2. Use a single edge razor blade scraper held at approximately 45° angle against the glass surface to scrape away food residue. Do not use a dull or nicked blade to scrape away residue. Apply only enough pressure to the scraper blade needed to dislodge and remove the food residue.
3. After scraping with the razor, clean the glass surface with cleaner as outlined for normal use cleaning above.

To clean the seal around the perimeter edge of the glass, wipe clean with a wet cloth. Do not use abrasive cleansers or scraping objects to clean the glass seal.

Aluminum Foil in Oven and Broiler

Aluminum foil when used improperly is a cause of many range fires. Make certain heating elements aren't covered or come in contact with aluminum foil.

Never cover a rack completely. A piece of foil slightly larger than the utensil can be placed on the rack beneath the utensil.

Backguard Control Panel or Any Painted or Aluminum Surfaces

Use a mild solution of soap and water. Do not use any harsh abrasives or cleaning powders that may scratch or mar the surface.

USER SERVICING

- Do not repair or replace any part of the appliance unless specifically recommended in this manual. All other servicing should be referred to a qualified technician.
- Disconnect the range from electrical supply before attempting to service or move it.
- If you pull the range out from the wall for any reason, make sure the rear leg is returned to its position in the anti-tip bracket when you push the range back.

Repair Parts

When repair parts are needed, contact the dealer from whom the range was purchased. In case your range was purchased from some source other than an appliance dealer you may prefer to contact the manufacturer of the range at the address shown in this manual.

MOISTURE

During initial heat-up of your range, the heat mixing with the cooler air in the oven cavity may produce fogging of the door glass or a collection of water on the door. To prevent this, open the oven door for the first few seconds of initial oven heat-up. This will allow moist air within the oven to escape without the forming of visible moisture on the range. The amount of moisture will depend upon the humidity of the air and water content of the food being cooked. Fogging and even dripping water will usually occur in geographic locations of high humidity.

OVEN VENT

The oven vent tube has been eliminated. By omitting the vent tube, a greater amount of moisture is retained; therefore, baked foods with greater appeal are created. The food itself retains more of its natural juices and has less tendency to dry out. The flavor is better.

ALIGNMENTS AND ADJUSTMENTS

Oven Door Spring Adjustments

The oven door springs are properly adjusted before leaving the factory. The springs should be adjusted to allow the door to remain open when pulled 90 degrees forward and yet pull the door tight against the oven front frame when closed. If adjustments should become necessary, remove the storage drawer and grasp spring with fingers, and pull downward. To give more tension, push toward rear of range and attach in first slot. To make spring adjustment on ranges without storage drawer, remove false panel and follow the same procedure.

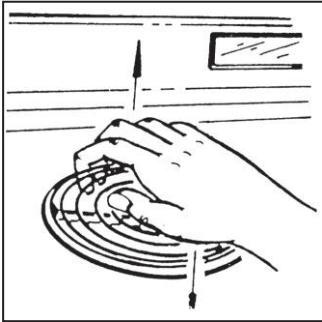

Make certain all surface elements are cool and all switches are in the OFF position prior to seating elements.

Seating Top Elements

The top element may need initial seating after installation of the stove or after they have been unplugged and re-installed. Palm the element as shown. Pick up on the rear section with your fingers, while at the same time, push down on the front of the element with the palm of your hand.

Storage

Your electric range is equipped with a storage area located beneath the oven cavity. To access this compartment, gently lift on the front edge of the “drop-down” panel and let it fall forward as shown. **ONLY LIFT ON THE FRONT EDGE OF THE PANEL SO AS TO NOT PINCH YOUR FINGERS.** Do not use this panel as a step or shelf.

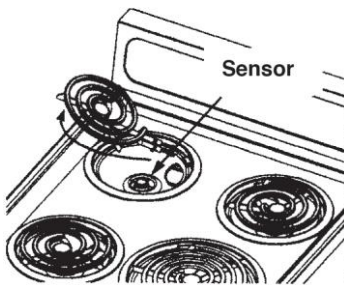
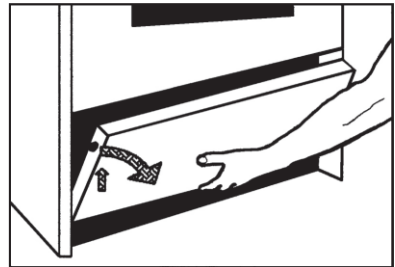

Brown HeatSense™

Some models may be equipped as a Brown HeatSense™ range with our exclusive Coil Logic safety system. It is designed to prevent overheating by utilizing an automatic cut-off sensor to power off the coil element if higher than necessary temperatures are detected. Once cooled, these sensors will disengage, allowing power to return to the coil element. The Coil Logic safety sensors are visible from the top of the burner bowl (refer to figure). When the coil elements are off and cool, the drip pans and Coil

Logic sensors can be cleaned with mild soap and warm water. Dry thoroughly before resuming use. Always keep all surfaces and subtop areas clean for optimal operation. **Do not use aluminum foil to line the drip pans.** Improper use of aluminum foils may result in shock or fire hazard.

LIFT OFF DOORS

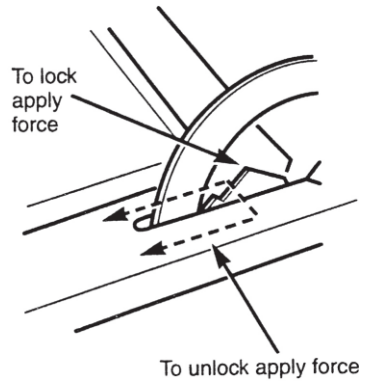
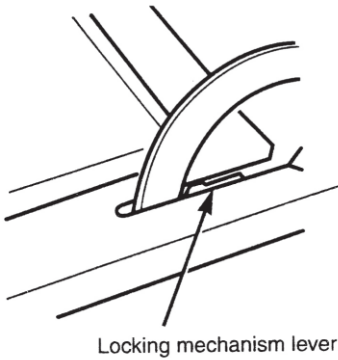

Lift-Off Oven Door (on some models)

The oven door is removable (on some models) but it is heavy. You may need help removing and replacing the door.

To remove the door, open it to the full open position. Raise the locking mechanism by applying force to the locking mechanism lever. Close the door until it stops against the locking mechanism. Grasp firmly on each side and lift the door straight up and off the hinges.

To replace the door, position the slots in the bottom of the door squarely over the hinges. Then lower the door slowly and evenly over both hinges at the same time.

Open the door to the full open position and press the locking mechanism back into its original position.

DO NOT ATTEMPT TO CLOSE THE DOOR UNTIL THIS STEP IS COMPLETE. THE HINGE OR DOOR COULD BE DAMAGED.

WIRING DIAGRAM FOR ELECTRIC RANGES

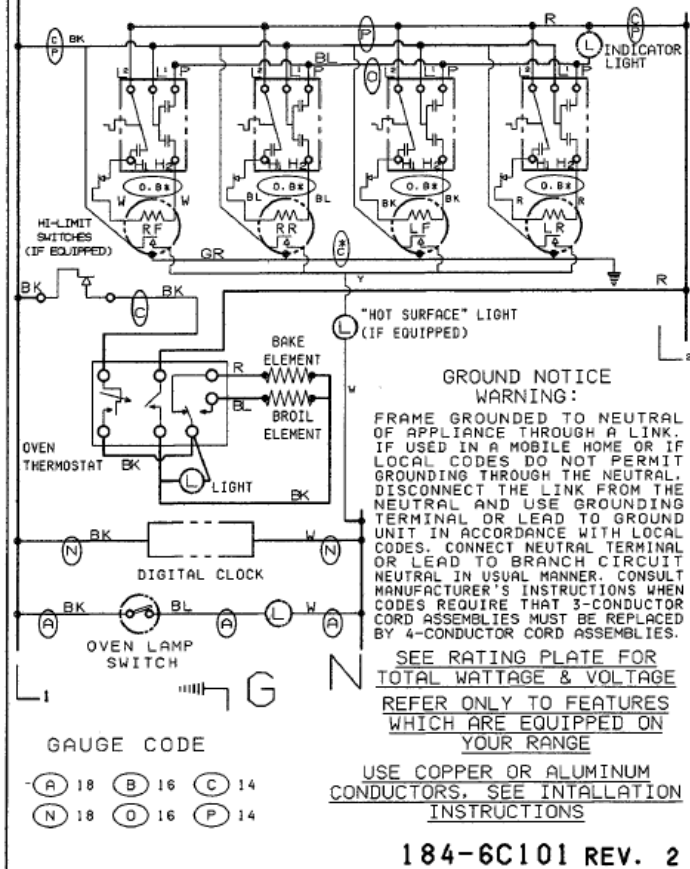

INSTALLATION INSTRUCTIONS BUILT-IN ELECTRIC RECESSED WALL OVENS

700 SERIES PIPING
AND INSTALLATION
NOTE: DO NOT INSTALL
BELOW WORK COUNTER

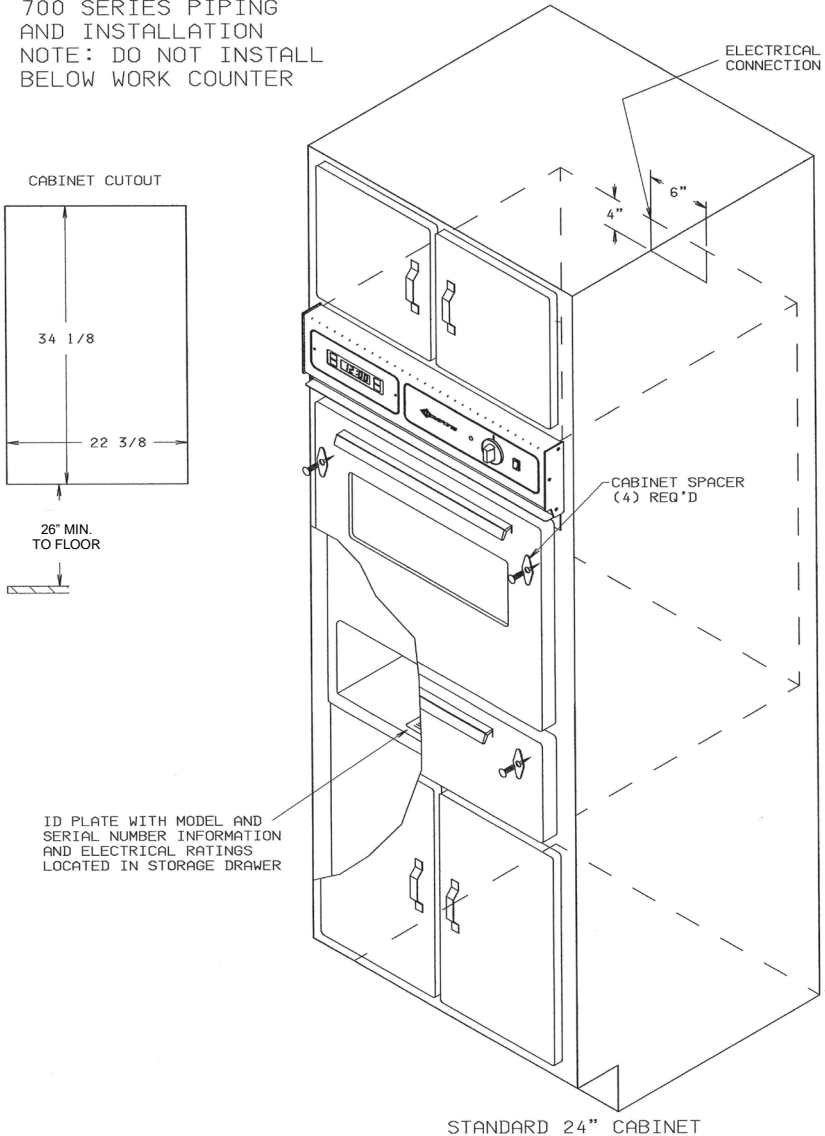

**IMPORTANT – Read and save these instructions.
Save for local electrical inspector's use.**

ELECTRIC RECESSED WALL OVEN

With the oven positioned in front of the cabinet opening, connect the leads extending from the conduit to the junction box.

Check all connections to see that they are tight and have not become loosened during transit.

After the above mentioned wire connections have been made at the junction box, secure the oven unit to the cabinet with wood screws. Be sure to use the cabinet spacer with the wood screw as a “washer” between the wood cabinet and the oven front frame.

POWER CONNECTIONS TO APPLIANCES

We suggest that you have the dealer where you purchased your new oven unit install it or have them arrange installation by a qualified electrician. Installation must conform with local codes. In addition, installation must conform with the National Electric Code NFPA70 latest edition.



Be sure electric power is OFF at the fuse (breaker) box until the unit is installed and ready to operate. See appliance rating plate for maximum K.W. and amperage ratings.

INSTALLATION

It is the responsibility of your installer to make certain that your oven unit is properly installed. Situations caused by improper installations are not covered under the warranty. Any expenses incurred due to such situations will not be paid by the manufacturer of the appliance.



ELECTRICAL GROUNDING INSTRUCTIONS

Appliances may be equipped with a three prong grounding plug for your protection against shock hazard and should be plugged directly into a properly grounded receptacle. Do not cut or remove the grounding prong from this plug.



INSURE PROPER GROUND EXISTS BEFORE USE.

110V-120V WALL OVENS

Models WEM715KW, TEM715DK, and TEM755KW are designed for 115V connections and ship with a pre-installed NEMA 5-15 plug. A 20 amp circuit is required.

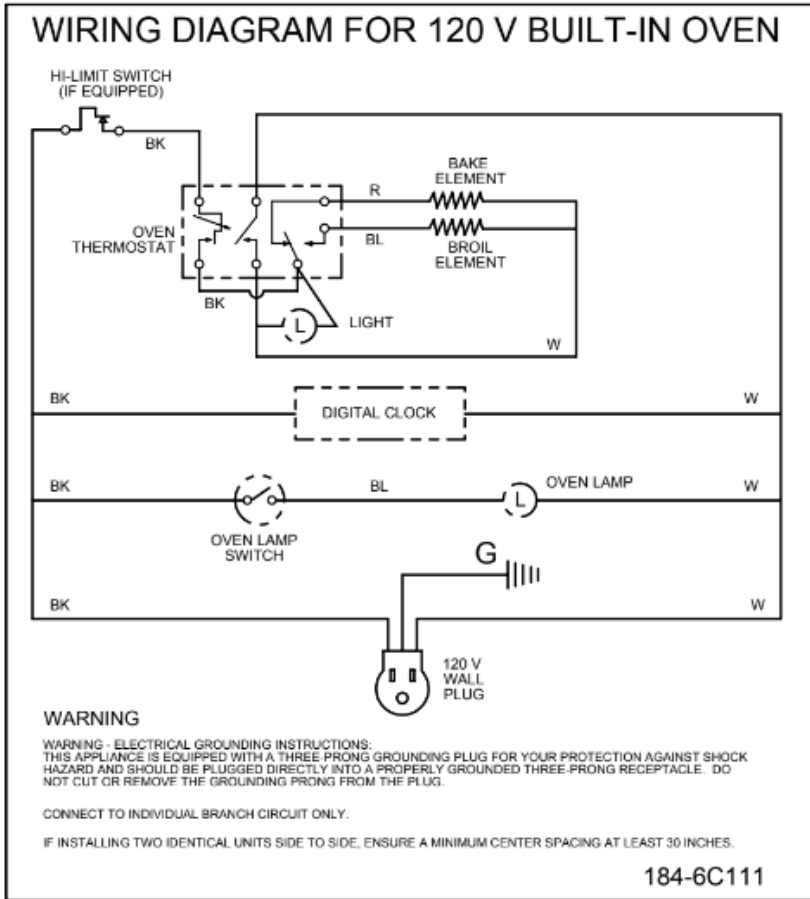

240V THREE-WIRE CONDUIT CONNECTION

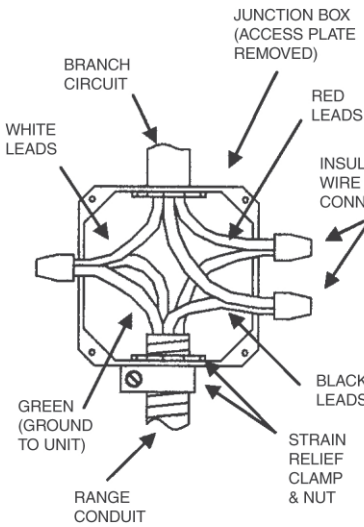

1. Remove the access plate to gain access to the electrical junction box.
2. Install the three-wire range conduit and an appropriate strain relief clamp through the hole in the junction box.
3. Use an appropriate insulated wire connector to connect the red and black wires from the range conduit to the corresponding red and black leads from the branch circuit.
4. Connect the green (ground) and white (neutral) wires from the range conduit to the white (neutral) lead from the branch circuit in like manner.
5. Secure the strain relief clamp around the conduit and tighten the nut against the wall of the junction box.
6. Tuck all wire leads into the junction box and replace the access plate removed earlier in step 1.

120/240 VAC

If local codes do not allow grounding through the neutral, refer to the illustration below of FOUR-WIRE CONDUIT CONNECTION.

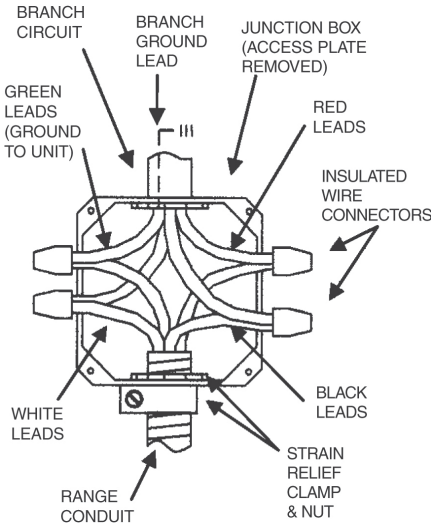

240V FOUR-WIRE CONDUIT CONNECTION

1. Remove the access plate to gain access to the electrical junction box.
2. Install the four-wire range conduit and an appropriate strain relief clamp through the hole in the junction box.
3. Use an appropriate insulated wire connector to connect the red, black, and white wires from the range conduit to the corresponding red, black, and white leads from the branch circuit.
4. Connect the green (ground) wire from the range conduit to the grounding lead from the branch circuit in like manner.
5. Secure the strain relief clamp around the conduit and tighten the nut against the wall of the junction box.
6. Tuck all wire leads into the junction box and replace the access plate removed earlier in step 1.

120/240 VAC

Effective January 1, 1996 the National Electrical Code requires that new construction (not existing) utilize a 4-conductor connection to an electric range.

NOTE: A 4-conductor cord is to be used when the appliance is installed in a mobile home or when local codes do not permit grounding through the neutral.

INSTALLATION INSTRUCTIONS BUILT-IN GAS AND ELECTRIC SURFACE UNITS (Cooktops)

CABINET OPENING

Prepare the cabinet accurately so your unit will fit properly. Below are cabinet cutout dimensions. The dimensions are for the unit to be mounted so the knobs are on the right side.

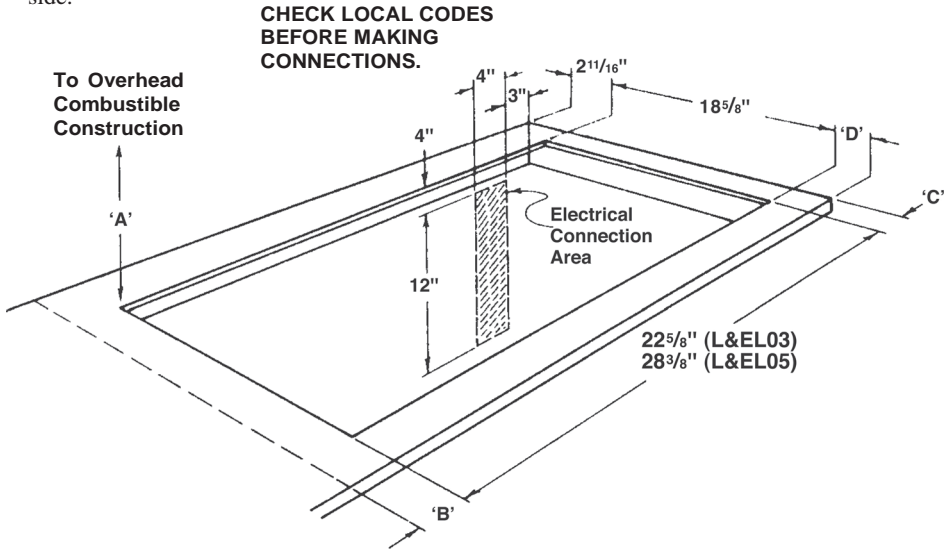

"A" 30" See CABINET PREPARATIONS Section.

"B" 2 ¹¹/₁₆" To Adjacent Vertical Combustible Surface.

"C" 1" To Adjacent Vertical Combustible Surface.

"D" 2 ⁵/₈" Minimum.



To eliminate the hazard of reaching over the heated surface units, cabinet storage space located above the surface units should be avoided. If cabinet storage is to be provided, the hazard can be reduced by installing a range hood that projects horizontally a minimum of 5 inches beyond the bottom of the cabinets.

INSTALLATION

It is the responsibility of your installer to make certain that your range is properly installed. Situations caused by improper installation are not covered under the warranty. Any expenses incurred due to such situations will not be paid by the manufacturer of the appliance.

**IMPORTANT – Read and save these instructions.
Save for local electrical inspector's use.**

ELECTRIC SURFACE UNITS

MOUNTING THE BUILT-IN TOP UNIT

Place unit in cabinet opening with the knobs, on the right side. Raise the top by lifting upward on the front edge of the main top. Secure unit to top of cabinets with four No. 8 screws through holes provided in the top flanges of the burner box. Make electrical connection. Electrical connection should conform to local requirements and codes.

POWER CONNECTIONS TO APPLIANCES

We suggest that you have the dealer where you purchased your new range install it or have them arrange installation by a qualified electrician. Installation must conform with local codes. In addition, installation must conform with the National Electric Code NFPA70 latest edition.



Be sure electric power is OFF at the fuse (breaker) box until the unit is installed and ready to operate. See appliance rating plate for maximum K.W. and amperage rating.

NOTE: A 4-conductor connection is to be used when the appliance is installed in a mobile home or when local codes do not permit grounding through the neutral.

THREE-WIRE CONDUIT CONNECTION

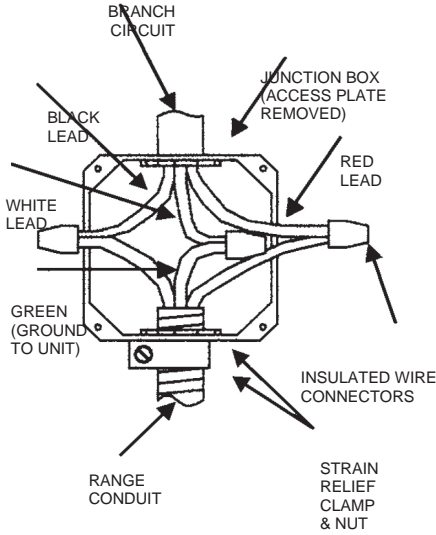

240 VAC

1. Remove the access plate to gain access to the electrical junction box.
2. Install the three-wire range conduit and an appropriate strain relief clamp through the hole in the junction box.
3. Use an appropriate insulated wire connector to connect the red and black wires from the range conduit to the corresponding red and black leads from the branch circuit.
4. Connect the green (ground) wire from the range conduit to the white (neutral) lead from the branch circuit in like manner.
5. Secure the strain relief clamp around the conduit and tighten the nut against the wall of the junction box.
6. Tuck all wire leads into the junction box and replace the access plate removed earlier in step 1.

If local codes do not allow grounding through the neutral, refer to the illustration below of FOUR-WIRE CONDUIT CONNECTION.

FOUR-WIRE CONDUIT CONNECTION

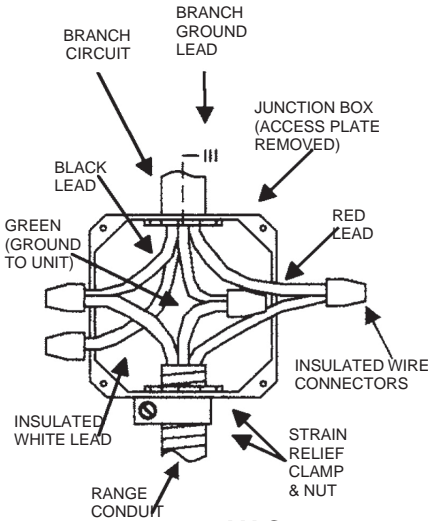

240 VAC

1. Remove the access plate to gain access to the electrical junction box.
2. Install the four-wire range conduit and an appropriate strain relief clamp through the hole in the junction box.
3. Use an appropriate insulated wire connector to connect the red and black wires from the range conduit to the corresponding red and black leads from the branch circuit.
4. Connect the green (ground) wire from the range conduit to the grounding lead from the branch circuit in like manner.
5. The white (neutral) lead from the branch circuit must be properly insulated away from all other leads.
6. Secure the strain relief clamp around the conduit and tighten the nut against the wall of the junction box.
7. Tuck all wire leads into the junction box and replace the access plate removed earlier in step 1.

Effective January 1, 1996 the National Electrical Code requires that new construction (not

existing) utilize a 4-conductor connection to an electric range.

NOTES

LIMITED WARRANTY

Within the 48 contiguous United States, for one year from the date of purchase, when this appliance is operated and maintained according to instructions attached to or furnished with the product, the warrantor will pay for factory-specified parts and repair labor to correct defects in materials or workmanship. Service must be provided by a designated service company. Outside the 48 states, all parts are warranted for one year from manufacturing defects. Plastic parts, shelves, and cabinets are warranted to be manufactured to commercially acceptable standards and are not covered from damage during handling or breakage.

ITEMS WARRANTOR WILL NOT PAY FOR:

1. Service calls to correct the installation of your appliance, to instruct you how to use your appliance, to replace or repair fuses, or to correct wiring or plumbing.
2. Service calls to repair or replace appliance light bulbs or broken glass shelves. Consumable parts (such as filters) are excluded from warranty coverage.
3. Damage resulting from accident, alteration, misuse, abuse, fire, flood, acts of God, improper installation, installation not in accordance with electrical or plumbing codes, or use of products not approved by the warrantor.
4. Replacement parts or repair labor costs for units operated outside the United States.
5. Repairs to parts or systems resulting from unauthorized modifications made to the appliance.
6. The removal and reinstallation of your appliance if it is installed in an inaccessible location or is not installed in accordance with published installation instructions.

DISCLAIMER OF IMPLIED WARRANTIES; LIMITATION OF REMEDIES

THE CUSTOMER'S SOLE AND EXCLUSIVE REMEDY UNDER THIS LIMITED WARRANTY SHALL BE PRODUCT REPAIR AS PROVIDED HEREIN. IMPLIED WARRANTIES, INCLUDING WARRANTIES OF MERCHANTABILITY OR FITNESS FOR A PARTICULAR PURPOSE, ARE LIMITED TO ONE YEAR. WARRANTOR SHALL NOT BE LIABLE FOR INCIDENTAL OR CONSEQUENTIAL DAMAGES. SOME STATES DO NOT ALLOW THE EXCLUSION OR LIMITATION OF INCIDENTAL OR CONSEQUENTIAL DAMAGES, OR LIMITATIONS ON THE DURATION OF IMPLIED WARRANTIES OF MERCHANTABILITY OR FITNESS, SO THESE EXCLUSIONS OR LIMITATIONS MAY NOT APPLY TO YOU. THIS WARRANTY GIVES YOU SPECIFIC LEGAL RIGHTS AND YOU MAY ALSO HAVE OTHER RIGHTS, WHICH VARY FROM STATE TO STATE.

The logo for Summit Appliance, featuring the word "SUMMIT" in a bold, black, sans-serif font. The letters are slightly shadowed to give a 3D effect. A registered trademark symbol (®) is located at the bottom right of the word.

Felix Storch, Inc.
An ISO 9001: 2015 registered company
770 Garrison Ave.
Bronx, NY 10701
www.summitappliance.com

For parts and accessory ordering,
troubleshooting, and helpful hints, visit
www.summitappliance.com